

TASCAM

D01244120B

DR-70D

Linear PCM Recorder for DSLR

Reference Manual

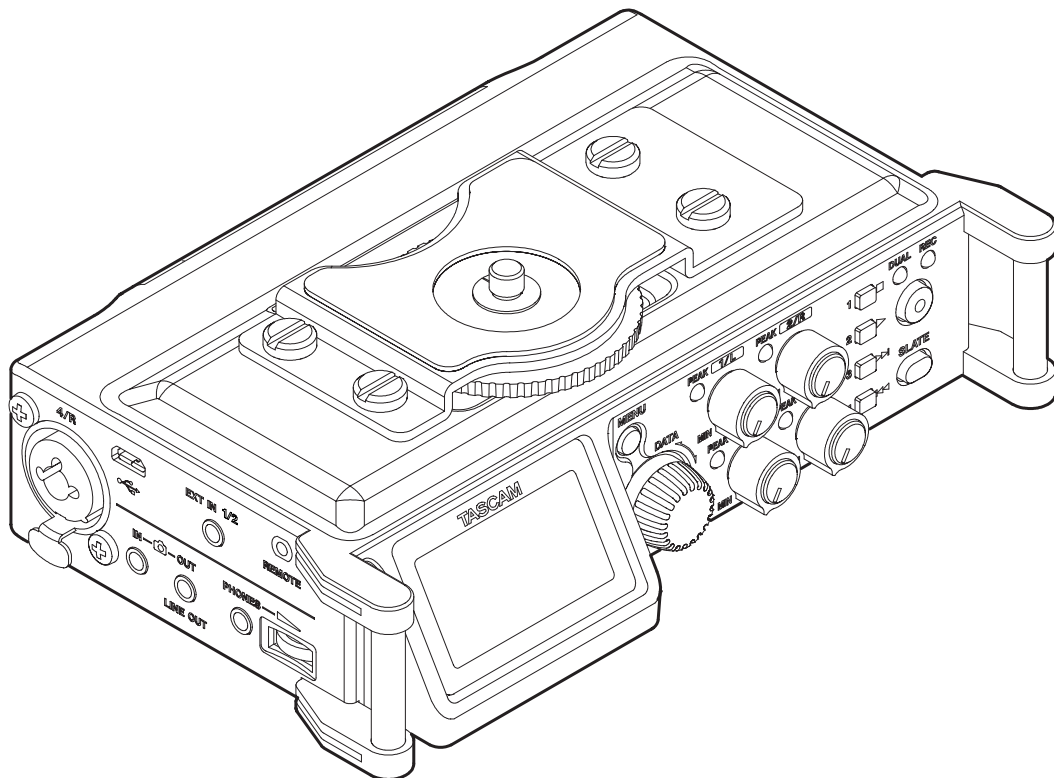

Contents

1 – Introduction	4	Setting the channels to record.....	18
Features	4	Adjusting the input balance	18
Conventions used in this manual	4	Adjusting the input level.....	19
About SD cards	5	Setting the recording input source	20
Precautions for use	5	Using plug-in power	20
2 – Names and Functions of Parts	6	Setting the input gain	20
Front panel	6	Using phantom power	21
Rear panel.....	6	Setting the phantom power voltage	21
Left side panel.....	7	Using the limiter	22
Right side panel.....	7	Using the low-cut filter	22
Top panel	8	Compensating for mic distances.....	23
Bottom Panel.....	8	Setting the phase of each channel.....	23
Home Screen	9	This shows the file type, format and sampling frequency used for recordings.....	23
Recording Screen.....	9	Recording (MONO/STEREO/2MIX)	24
Menu item list.....	10	Starting recording.....	24
Using menus.....	11	File names when recording in MONO	24
Basic operation	11	File names when recording in STEREO/2MIX...24	
3 – Preparation.....	12	Creating a new file without interrupting recording (track incrementing)	24
Powering the unit	12	Manual track incrementation during recording	24
Power sources	12	Automatic track incrementation during recording.....	24
Using AA batteries	12	Simultaneously recording two files at different input levels (DUAL REC)	25
Using an AC adapter (sold separately).....	12	Enabling dual recording	25
Using an external battery pack (sold separately).....	12	Starting dual recording.....	25
Using USB bus power.....	13	Dual recording file names.....	25
Turning the unit on and off (putting it in standby)	13	Using the auto tone function	26
Turning the unit on.....	13	Setting the auto tone function	26
Turning the unit off (putting it in standby).....	13	Set the volume of auto and slate tones	26
Resume function	13	Recording slate tones.....	26
Setting the date and time	14	Moving to slate tone positions.....	26
Inserting and removing SD cards.....	14	Using mid-side microphones	27
Inserting a card	14	Recording duration	28
Removing a card.....	14	5 – Working with Files and Folders (BROWSE screen).....	29
SD card write protection switches	15	BROWSE screen navigation	29
Preparing an SD card for use	15	Icons on the BROWSE screen.....	29
Connecting monitoring equipment	15	File operations	29
Monitoring.....	15	Folder operations.....	30
Selecting the monitored signal	15	Creating a new folder	30
Setting the output gain	16	6 – Playback.....	31
Adjusting the playback volume.....	16	Playing recordings.....	31
Camera connection and attachment	16	Pausing.....	31
Setting the inputs.....	17	Stopping.....	31
Recording with the built-in stereo mic.....	17	Searching backward and forward.....	31
Connecting microphones	17	Selecting files for playback (skipping).....	31
Recording an external device (LINE IN).....	17	Playing files created with dual recording.....	31
Using the top panel accessory shoe	17		
4 – Recording	18		
Recording formats.....	18		
Setting where to save files.....	18		

7 – Connecting with a Computer	32
Transferring files to a computer	32
Transferring files from a computer	32
Disconnecting from a computer	32
8 – Settings and Information	33
Viewing information	33
File information page (PROJECT).....	33
Card information page (CARD).....	33
System information page.....	33
System Settings	34
Setting the automatic power saving function ..	34
Setting the backlight	34
Adjusting the display contrast.....	34
Restoring the factory settings.....	34
Formatting an SD card	34
Setting the battery type.....	34
Setting the file name format	35
File name format	35
Setting the WORD item.....	35
Initializing the count	35
9 – Using the REMOTE jack.....	36
Using a footswitch (TASCAM RC-3F).....	36
Making footswitch settings.....	36
Footswitch uses	36
Using a remote control (TASCAM RC-10)	36
Making remote control settings	36
Remote control uses	36
10 – Messages	37
11 – Troubleshooting.....	38
12 – Specifications	39
Ratings	39
Input/output ratings.....	39
Analog audio input and output ratings.....	39
Control input/output ratings	39
Audio performance	39
Requirements for connected computers.....	40
General	40
Dimensional drawings	41

1 – Introduction

Features

This recorder includes audio inputs and outputs that are suitable for use with digital single-lens reflex (DSLR) cameras, enabling the recording of high-quality audio with DSLR video.

- Compact audio recorder that uses SD/SDHC/SDXC cards as recording media
- TASCAM original High Definition Discrete Architecture (HDDA) microphone preamps provide high-quality recording inputs
- In addition to ordinary stereo recording, simultaneous recording of up to four channels is possible
- Four channels can be mixed down to two for stereo output
- Recording levels can be adjusted independently for the **1/L**, **2/R** **3/L** and **4/R** channels
- Dual recording function allows two files to be recorded simultaneously at different levels
- 44.1/48/96 kHz, 16/24-bit, linear PCM (WAV format) recording possible
- Broadcast Wave Format (BWF) supported as WAV recording format
- XLR mic/line inputs can provide phantom power (24V/48V) and TRS mic/line inputs (exclusive use) support +24dBu input when set to LINE
- Stereo mini jack input supports mics that require plug-in power, allowing the input of video mics and other high-output mics (+10dBV maximum input level)
- Slate tone functions (automatic/manual) simplify synchronization of video files when editing
- CAMERA OUT connector allows the high-quality audio from this unit to be output to a DSLR camera for recording
- CAMERA IN connector enables convenient monitoring of audio from a DSLR camera
- Mid-side decoding function can be used with MS mics
- Track incrementing function allows a recording to be split by creating a new file when desired
- Limiter function automatically reduces parts where the input level is too high to suitable levels
- Low cut filter conveniently reduces low-frequency noise
- Delay function that eliminates time lags caused by differences in the distances of two sets of inputs from the sound source
- Tone search function enables moving between tone insertion points
- File name format can be set to use a user-defined word or the date
- Resume function to memorize the playback position before the unit is turned off (enter standby)
- 3.5mm (1/8") line/headphones output jack
- 128x64 dot-matrix LCD with backlight
- Micro-B USB 2.0 port
- Operates on 4 AA batteries, an AC adapter (TASCAM PS-P515U sold separately), external battery pack (TASCAM BP-6AA sold separately) or USB bus power
- Tripod mounting thread (bottom) and DSLR screw attachment that allows attachment and removal with a coin (top)
- Dedicated remote control jack (for use with RC-10 and RC-3F (sold separately)
- Hold function to prevent accidental operation
- Guards on the front left and right sides protect the screen

This product has a Blackfin® 16/32-bit embedded processor made by Analog Devices, Inc. This processor controls the unit's digital signal processing.

Inclusion of this Blackfin® processor in the product increases its performance and reduces its power consumption.

Conventions used in this manual

The following conventions are used in this manual.

- When we refer to buttons, connectors and other parts of this unit, we use a bold font like this: **MENU** button.
- When we show messages, for example, that appears on the unit's display, the typeface looks like this: INPUT.
- SD, SDHC and SDXC memory cards are called "SD cards".
- Information shown on the computer display is written like this "OK".
- As necessary, additional information is provided under TIP, NOTE and CAUTION headings.

TIP

These are tips about how to use the unit.

NOTE

These provide additional explanations and describe special cases.

CAUTION

Failure to follow these instructions could result in injury, damage to equipment or lost recording data, for example.

Information and various data about products provided in this manual are provided merely as examples. They do not provide a guaranty against violations of third-party intellectual property rights or other rights related to them. Therefore, please be aware that our company will bear no liability for violations of third-party intellectual property rights or responsibility for liability that results from the use of these products.

Third-party copyrighted materials cannot be used without permission of the rights holder in accordance with copyright law for uses other than personal enjoyment, for example. Please use the equipment appropriately.
Our company will bear absolutely no liability related to user activity that infringes on property rights.

About SD cards

This unit uses SD cards for recording and playback.

You can use 64MB–2GB SD cards, 4GB–32GB SDHC cards and 48GB–128GB SDXC cards with this unit.

A list of SD cards that have been confirmed for use with this unit can be found on the TEAC Global Site (<http://teac-global.com/>). Please check this site or contact TASCAM customer support.

Precautions for use

SD cards are delicate media. In order to avoid damaging a card or the card slot, please take the following precautions when handling them.

- Do not leave them in extremely hot or cold places.
- Do not leave them in extremely humid places.
- Do not let them get wet.
- Do not put things on top of them or twist them.
- Do not hit them.
- Do not remove or insert a card during recording, playback, data transmission or other access.
- When carrying a card, please put it inside a card case, for example.

2 – Names and Functions of Parts

Front panel

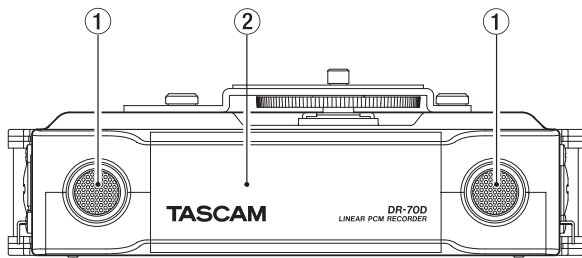

- ① **Built-in stereo microphone**
Omnidirectional stereo electret condenser microphone.
- ② **Front cover**
This is the cover for the battery case and SD card slot.

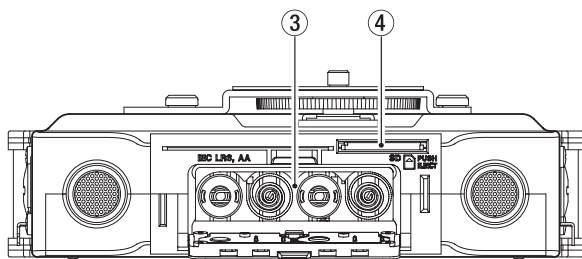

- ③ **Battery compartment**
Install batteries (4 AA) in this compartment to power the unit. (See “Using AA batteries” on page 12.)
- ④ **SD card slot**
Insert an SD card here.

Rear panel

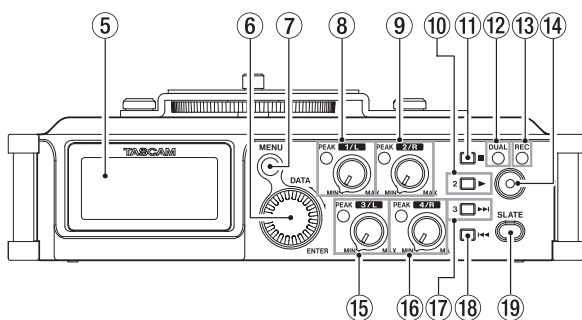

- ⑤ **Display**
Shows a variety of information.
- ⑥ **DATA dial (ENTER)**
Turn to select items and change values on setting screens. Use also to change the playback position in a file.
Push this dial to confirm selections on setting screens and to answer “YES” to confirmation pop-up messages.
Turn the **DATA** dial while the Home Screen is open to move between the positions of slate tones that have been inserted in the file. If no slate tone has been inserted in the file, doing this will move to the next file.
Press and hold this dial when stopped to switch the signal monitored.

- ⑦ **MENU button**
When the Home Screen is open, press this button to open the MENU screen.
When a setting screen is open, press to move up one level in the menu. When the MENU screen is open, press to return to the Home Screen.
- ⑧ **1/L knob and PEAK indicator**
Use this knob to adjust the input level from the 1/L connector on the left side of the unit.
The **1/L PEAK** indicator lights when the 1/L input level is about to cause distortion. This also lights if distortion occurs in the analog circuitry during mic input. This will not light, however, if distortion occurs in the analog circuitry during line input. (See “Adjusting the input level” on page 19.)
- ⑨ **2/R knob and PEAK indicator**
Use this knob to adjust the input level from the 2/R connector on the left side of the unit.
The **2/R PEAK** indicator lights when the 2/R input level is about to cause distortion. This also lights if distortion occurs in the analog circuitry during mic input. This will not light, however, if distortion occurs in the analog circuitry during line input. (See “Adjusting the input level” on page 19.)
- ⑩ **1/■ button**
Press this button during playback to cause the playback to pause at the current position. Press this button when paused to return to the beginning of the playback file.
Press this button during recording to stop recording.
When the BASIC screen or INPUT screen is open, use this to select the channel to which the setting items shown apply.
When a setting screen is open, press this button to return to the Home Screen. Use this button to answer “NO” to a confirmation message.
- ⑪ **2/▶ button**
When the Home Screen is open and playback is stopped, press this button to start playback.
When a file or folder is selected in the BROWSE screen, press this button to return to the Home Screen and play that file or the first file in the folder from the beginning.
When the BASIC screen or INPUT screen is open, use this to select the channel to which the setting items shown apply.
- ⑫ **DUAL indicator**
This lights orange when in dual recording mode.
- ⑬ **REC indicator**
This lights red when recording.
- ⑭ **Record (●) button**
Press when stopped to start recording.
Press when recording to stop recording.
- ⑮ **3/L knob and PEAK indicator**
Use this knob to adjust the input level from the 3/L connector on the left side of the unit.
The **3/L PEAK** indicator lights when the input level is about to cause distortion. This also lights if distortion occurs in the analog circuitry during mic input. This will not light, however, if distortion occurs in the analog circuitry during line input. (See “Adjusting the input level” on page 19.)
- ⑯ **4/R knob and PEAK indicator**
Use this knob to adjust the input level from the 4/R connector on the right side of the unit.
The **4/R PEAK** indicator lights when the input level is about to cause distortion. This also lights if distortion occurs in the analog circuitry during mic input. This will not light,

2 – Names and Functions of Parts

however, if distortion occurs in the analog circuitry during line input. (See “Adjusting the input level” on page 19.)

17 3/▶▶▶ button

Press this button during playback or when playback is stopped to skip to the beginning of the next track.

Press and hold this button to search forward.

When the BASIC screen or INPUT screen is open, use this to select the channel to which the setting items shown apply.

On the setting screens, use this button to move the cursor right.

On the BROWSE screen, press this button to move down a level. If a file is selected, the file is loaded and the Home Screen reopens.

18 4/◀◀◀ button

During playback or when stopped in the middle of a file, press to return to the beginning of the file.

If you press this button when a track is stopped at its beginning, the unit will skip to the beginning of the previous track.

Press and hold this button to search backwards.

When the BASIC screen or INPUT screen is open, use this to select the channel to which the setting items shown apply.

On the setting screens, use this button to move the cursor left.

On the BROWSE screen, press this button to move up a level.

19 SLATE button

Press and hold this button during recording to record a slate tone. (See “Recording slate tones” on page 26.)

Left side panel

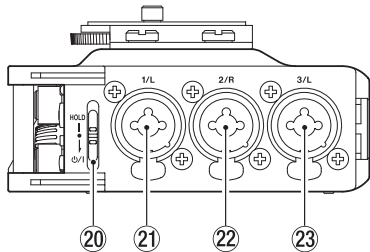

NOTE

When connecting and using plugs from external devices, do not apply excessive force to the plugs. In particular, be careful not to apply too much force when using a standard to mini plug adapter. Doing so could damage the equipment.

20 HOLD/⏻ / I switch

Slide this switch (toward the arrow) and hold it down to turn the unit on/off.

Set it in the up position to activate the hold function. All buttons are inoperative when hold is ON.

21 1/L connector (XLR/TRS)

This is a balanced analog XLR/TRS combo jack for microphone and line level inputs.

XLR (1: GND, 2: HOT, 3: COLD)

TRS (Tip: HOT, Ring: COLD, Sleeve: GND)

22 2/R connector (XLR/TRS)

This is a balanced analog XLR/TRS combo jack for microphone and line level inputs.

XLR (1: GND, 2: HOT, 3: COLD)

TRS (Tip: HOT, Ring: COLD, Sleeve: GND)

23 3/L connector (XLR/TRS)

This is a balanced analog XLR/TRS combo jack for microphone and line level inputs.

XLR (1: GND, 2: HOT, 3: COLD)

TRS (Tip: HOT, Ring: COLD, Sleeve: GND)

CAUTION

- *Confirm that phantom power is OFF before connecting a line level device to the 1/L, 2/R, 3/L or 4/R connector. If you connect a line level device while phantom power is being supplied, that device and this unit could be damaged.*
- *Before connecting a condenser mic to or disconnecting one from the 1/L, 2/R, 3/L or 4/R connector, confirm that the phantom power for that jack is OFF. If you connect or disconnect a mic while phantom power is being supplied, that mic and this unit could be damaged.*
- *Do not connect an unbalanced dynamic mic to an XLR connector when phantom power is being supplied. Doing so could damage that mic and this unit.*

Right side panel

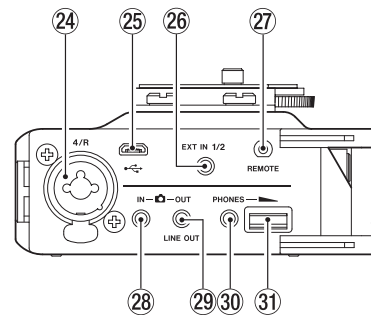

NOTE

When connecting and using plugs from external devices, do not apply excessive force to the plugs. In particular, be careful not to apply too much force when using a standard to mini plug adapter. Doing so could damage the equipment.

24 4/R connector (XLR/TRS)

This is a balanced analog XLR/TRS combo jack for microphone and line level inputs.

XLR (1: GND, 2: HOT, 3: COLD)

TRS (Tip: HOT, Ring: COLD, Sleeve: GND)

25 Micro USB port

Use the included USB cable to connect with a computer USB port. (See “7 – Connecting with a Computer” on page 32.)

Power can be supplied through the USB cable provided with the unit or an AC adapter (TASCAM PS-P515U sold separately).

CAUTION

The unit should be connected directly to the computer, not through a USB hub.

26 EXT IN 1/2 connector (3.5mm stereo mini jack)

This supports stereo mini jack input from a mic or external device.

This jack can provide plug-in power.

TRS (Tip: HOT, Ring: COLD, Sleeve: GND)

2 – Names and Functions of Parts

- 27 **REMOTE connector (2.5mm TRS jack)**
Connect a TASCAM RC-3F footswitch or TASCAM RC-10 wired remote control (both sold separately) here to enable remote starting and stopping of playback and other functions. A remote control can be used to start, stop and otherwise operate the unit. (See “9 – Using the REMOTE jack” on page 36.)
- 28 **IN connector (3.5mm stereo mini jack)**
Connect to the audio output of a camera.
Refer to the camera's operation manual to identify this connector on the camera. (See “Camera connection and attachment” on page 16.)
- 29 **OUT/LINE OUT jack (3.5mm stereo mini jack)**
Use a stereo mini jack cable to connect this to the external input jack of a camera or line input jack of other equipment.
Use the **OUTPUT LEVEL** item on the **MONITOR SETTING** screen to adjust the volume output from this jack.
Refer to the camera's operation manual to identify this connector on the camera. (See “Camera connection and attachment” on page 16.)
- 30 **PHONES jack (3.5mm stereo mini jack)**
Connect stereo headphones to this stereo mini jack.
Use the **PHONES** control to adjust the volume.
- 31 **PHONES volume control**
Use to adjust the volume output from the **PHONES** jack.

CAUTION

*Before connecting headphones, lower the **PHONES** volume to the minimum level. Failure to do so could result in a sudden loud noise that could harm hearing, for example.*

Top panel

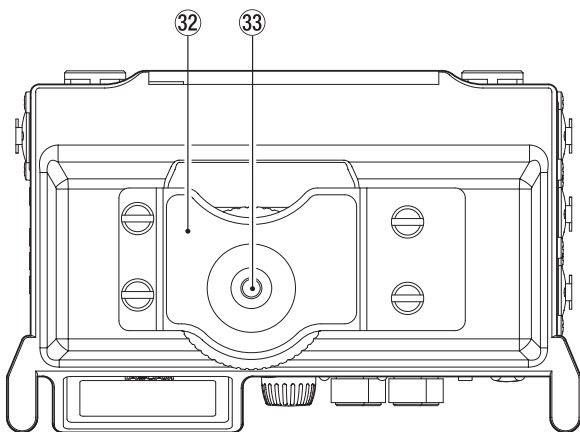

- 32 **DSLR camera attachment bracket**
Use a DSLR mounting screw with this bracket, which is pre-installed on the unit.
If you do not want to use this bracket, use a coin or other tool to remove the four attachment screws.
- 33 **DSLR mounting screw (1/4-inch)**
Use to attach this unit to the bottom of a camera or a rack that supports camera mounting screws, for example.

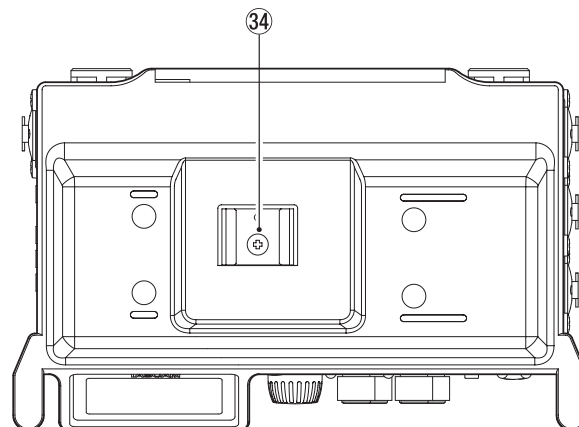

- 34 **Accessory shoe**
You can use the accessory shoe by removing the included DSLR attachment bracket

Bottom Panel

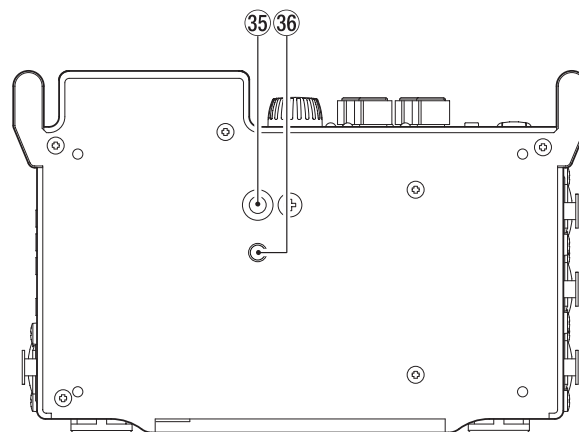

- 35 **Tripod mounting thread (1/4-inch)**
Use to attach this unit to a tripod.

CAUTION

- *Tighten the unit securely to the tripod or microphone stand to prevent it from falling off.*
- *When using this unit attached to a tripod or microphone stand, place the tripod or stand on a level surface.*
- *Some tripods have different screw specifications that make direct connection impossible. Use a commercially-available adapter with such tripods.*

- 36 **Video camera pin hole**
When using a tripod with a pin for video cameras, align this hole with the pin when attaching the unit to the tripod.

2 – Names and Functions of Parts

Home Screen

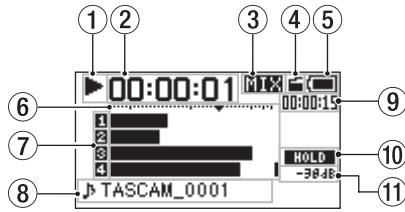

- ① **Recorder operation status**
This icon shows the recorder operation status.

Indicator	Meaning
■	Stopped
	Paused
▶	Playing back
▶▶	Searching forward
◀◀	Searching backward
▶▶	Skipping to the beginning of the next track
◀◀	Skipping to the beginning of the current or previous track

- ② **Elapsed time**
This shows the elapsed time (hours: minutes: seconds) of the current file.

- ③ **Monitoring mode**
This shows what audio is now being monitored.

Indicator	Meaning
MIX	CH1-4 mix sound or dual recording mode main file
CAM	📷 IN jack sound input

- ④ **Auto tone function status**
This icon shows whether the auto tone function is on or off. (See “Using the auto tone function” on page 26.)
No icon: Auto tone off

🔊: Auto tone on

- ⑤ **Power supply status**
A battery icon appears when power is supplied by batteries. The battery icon shows the amount of power remaining with 10 levels (🔋 → 🔋 → 🔋).

When the 🔋 icon has no bars, the batteries are almost dead and the unit will soon turn off (enter standby).

When using a TASCAM PS-P515U AC adapter (sold separately) or USB bus power, 🔌 appears.

NOTE

Sometimes a “Battery Low” warning appears when recording or conducting other demanding operations even before the battery power has been depleted.

- ⑥ **Level meters**
These show the levels of the input and playback signals.

- ⑦ **Recording status**
These show the recording on/off status of each channel. (See “Setting the channels to record” on page 18.)

1: Recording off

🔴: Recording on

- ⑧ **Project name**
This shows the name of the project playing back.
A project is a group of files used for recording/playback.

- ⑨ **Remaining time**
This shows the elapsed time (hours: minutes: seconds) of the current file.

When stopped, this shows the remaining recording time of the SD card (hours: minutes: seconds).

- ⑩ **HOLD/⏻ / I switch status**
This shows the status of the **HOLD/⏻ / I** switch.

🔴 HOLD: **HOLD** switch off

🟢 HOLD: **HOLD** switch on

- ⑪ **Peak value in decibels (dB)**
The maximum level that occurs in a fixed period of time is displayed in decibels.

Recording Screen

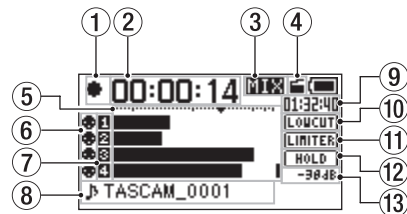

- ① **Recorder operation status**
This icon shows the recorder operation status.

Indicator	Meaning
●	Recording

- ② **Elapsed recording time**
The elapsed recording time of the file appears as hours: minutes: seconds.

- ③ **Monitoring mode**
This shows what audio is now being monitored.

Indicator	Meaning
MIX	CH1-4 mix sound or dual recording mode main file
CAM	📷 IN jack sound input

- ④ **Auto tone function status**
This icon shows whether the auto tone function is on or off. (See “Using the auto tone function” on page 26.)

No icon: Auto tone off

🔊: Auto tone on

- ⑤ **Level meters**
These show the input signal levels.

A ▼ mark is shown at the -16dB position on the scale as a guide for input level adjustment.

- ⑥ **Phantom power status**
This shows the phantom power on/off setting. (See “Using phantom power” on page 21.)

No icon: Phantom power off

🔊: Phantom power on

2 – Names and Functions of Parts

⑦ Recording status

These show the recording on/off status of each channel. (See “Setting the channels to record” on page 18.)

⏏ : Recording off

⏏ : Recording on

⑧ Project name

This shows the name of the project for the recorded files.

⑨ Remaining recording time

The remaining recording time on the SD card is shown in hours: minutes: seconds according to the recording mode, sampling frequency and recording format settings.

⑩ Low cut filter on/off status

This shows whether the low cut filter is on or off. (See “Using the low-cut filter” on page 22.)

This icon is shown as light letters on a dark background if the low-cut filter is set to 40Hz, 80Hz, 120Hz, 180Hz or 220Hz for channel 1, 2, 3 or 4.

LOWCUT : Low cut filter off

LOWCUT : Low cut filter on

⑪ Limiter function status

This shows the limiter function setting. (See “Using the limiter” on page 22.)

This icon is shown as light letters on a dark background if the limiter function setting is set to MONO or LINK for channel 1, 2, 3 or 4.

LIMITER : limiter off

LIMITER : Limiter on

⑫ HOLD/⏏ / I switch status

This shows the status of the HOLD/⏏ / I switch.

HOLD : HOLD switch off

HOLD : HOLD switch on

⑬ Peak value in decibels (dB)

Peak input level values are shown in decibels.

Menu item list

Press the **MENU** button to open the **MENU** screen.

This list provides an overview of the various menu items.

Menu item	Function	Page
BASIC	Make recording settings	see page 18
		see page 18
		see page 19
		see page 20
		see page 20
MONITOR	Make monitoring output settings	see page 16 see page 15
INPUT	Make input settings	see page 20
		see page 22
		see page 22
		see page 23
		see page 23
RECORD	Make recording format settings	see page 23 see page 25
SLATE	Make slate tone settings	see page 26 see page 26
MIC	Make mic settings	see page 21 see page 27
BROWSE	Work with SD card files and folders	see page 30
OTHERS	Show submenu items	

The **OTHERS** submenu appears when **OTHERS** is selected in the **MENU** screen. The submenu items are as follows.

Submenu item	Function	Page
SYSTEM	Make system settings for the unit	see page 34
BATTERY	Set the type of batteries	see page 34
INFORMATION	View information about files, the SD card and the system	see page 33
FILE NAME	Make file name settings	see page 35
DATE/TIME	Make date and time settings	see page 14
REMOTE	Make settings for the TASCAM RC-3F footswitch and TASCAM RC-10 wired remote control (both sold separately)	see page 36 see page 36

CAUTION

*The **MENU** screen will not appear when recording.*

Using menus

We explain how to change recording settings in this example.

1. Press the **MENU** button to open the **MENU** screen.

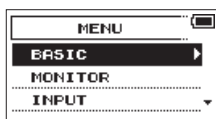

2. Turn the **DATA** dial to select (highlighted as light text on a dark background) a menu item, and press the **DATA** dial or **3/▶▶▶** button to open the setting screen.

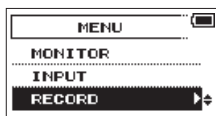

RECORD selected

3. Turn the **DATA** dial to select (highlight) a menu item to be set.

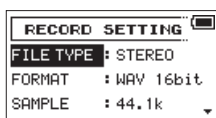

FILE TYPE selected

4. Press the **DATA** dial or **3/▶▶▶** button to move the cursor to highlight the value of the setting.

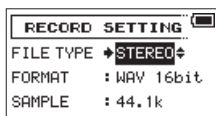

5. Turn the **DATA** dial to change the setting.
6. Press the **DATA** dial or **4/◀◀◀** button to set a different item in the same menu.
This enables you to select a new item. Turn the **DATA** dial again to select an item to be set.
7. Repeat steps 3 to 6 as necessary to set each item.
8. Press the **MENU** button to return to the **MENU** screen (or **OTHERS** screen).
Press the **1/■** button to return to the Home Screen.

NOTE

*When the **BASIC** or **INPUT** screen is open, press the **MENU** button again to return to the Home Screen.*

Basic operation

Use the following buttons to operate the various screens.

■ MENU button

Opens the **MENU** screen.

■ 1/■ button

When a setting screen is open, press the **1/■** button to return to the Home Screen.

Use this to answer "NO" to confirmation pop-up messages.

■ DATA dial

Turn the **DATA** dial to select items and change values on setting screens. You can also turn the **DATA** dial to change the file playback position.

Push the **DATA** dial to confirm selections on setting screens and to answer "YES" to confirmation pop-up messages.

■ 3/▶▶▶ button

Use this to move the cursor (highlighted area) to the right on the screen, and to move down a level on the **BROWSE** screen.

■ 4/◀◀◀ button

Use this to move the cursor (highlighted area) to the left on the screen, and to move up a level on the **BROWSE** screen.

3 – Preparation

Powering the unit

Power sources

This unit can be powered by four AA batteries, a TASCAM PS-P515U AC adapter (sold separately) or the included USB cable (USB bus power).

This unit can use alkaline dry cell or Ni-MH AA batteries.

Using AA batteries

Open the front cover and battery compartment cover. Install 4 AA batteries in the compartment with the ⊕ and ⊖ marks as shown. Then, close the battery compartment cover and front cover.

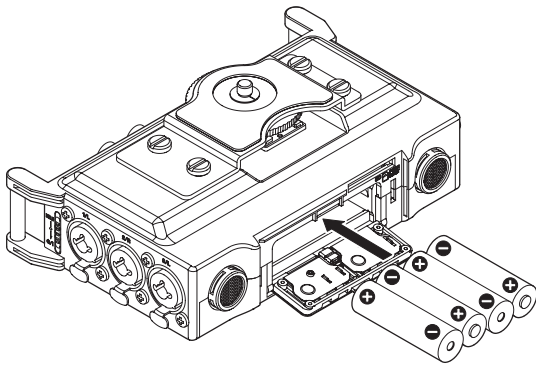

When using AA batteries, set the type of battery in order to accurately show the amount of power remaining and allow the unit to accurately determine whether power is available for proper operation. (See “Setting the battery type” on page 34.)

CAUTION

- This unit cannot use manganese dry cell AA batteries.
- This unit cannot recharge Ni-MH AA batteries. Use a commercially available recharger.

NOTE

A great amount of power is required to provide phantom power to a condenser microphone. If you use a condenser microphone while running the unit on AA batteries (NiMH rechargeable or alkaline dry cell), the operation time will be shortened.

If you need to operate the unit for a long time, use a TASCAM PS-P515U AC adapter or TASCAM BP-6AA external battery box (both sold separately) to power the unit.

Using an AC adapter (sold separately)

Connect the USB cable to the TASCAM PS-P515U AC adapter and the unit's USB port as shown in the illustration.

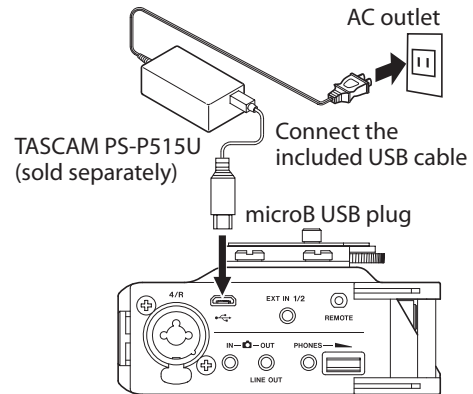

NOTE

When both batteries are installed and the AC adapter is connected, power will be supplied from the AC adapter.

CAUTION

- Never use any adapter other than the designated TASCAM PS-P515U AC adapter. Use of a different adapter could cause malfunction, fire or electric shock.
- Noise may occur when recording with a microphone if the unit is too close to the AC adapter. In such a case, keep sufficient distance between the AC adapter and the unit.

Using an external battery pack (sold separately)

Connect a TASCAM BP-6AA external battery pack (designed for use with this unit and sold separately) to the recorder with the included USB cable as shown in the illustration. For details, see the BP-6AA Owner's Manual.

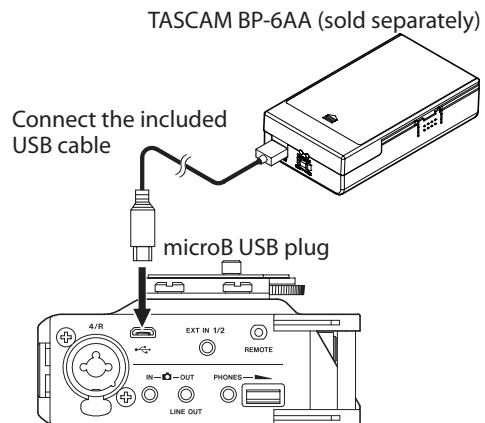

CAUTION

This unit cannot detect the remaining battery charge of a BP-6AA. If you use a BP-6AA to operate this unit without batteries in the unit itself, it might stop operating suddenly if the battery pack runs out of power.

In order to avoid problems, put batteries with sufficient charge into this unit before connecting and using a BP-6AA.

Using USB bus power

Connect the unit to a computer using the included USB cable as shown in the illustration.

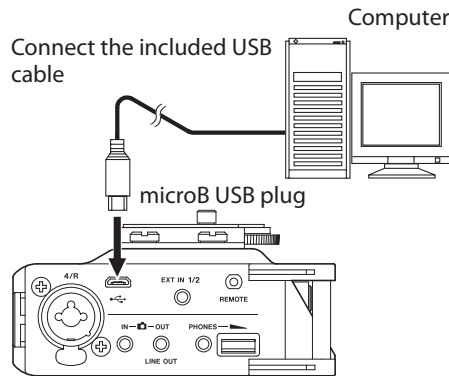

The **USB SELECT** screen appears when the unit is connected by USB and when the unit is turned on if the USB cable is already connected. On this screen, choose between USB bus power supply or USB connection with the computer.

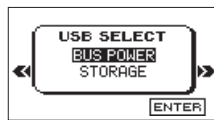

Turn the **DATA** dial to select **BUS POWER** and press the **DATA** dial to start power supply through the USB port and return to the Home Screen.

NOTE

Power is supplied from the USB port even if the connected unit contains batteries (USB bus power prioritized).

CAUTION

- Depending on the USB bus power specifications of the computer, this unit might not function when connected to a computer by USB cable. In this case, use a TASCAM PS-P515U AC adapter (sold separately) or batteries.
- This unit does not support computer power conservation and sleep functions. When powering the unit using the USB bus power of a computer, always turn such functions off.

Turning the unit on and off (putting it in standby)

CAUTION

- The unit enters standby mode if turned off when the unit is operating on power from a TASCAM PS-P515U AC adapter (sold separately) or a computer USB bus.
- Turn down the volume of any monitoring system connected to the unit before turning the unit on or off (standby).
- Do not wear connected headphones when turning the unit on or off. Noise could damage the speakers or harm your hearing.

Turning the unit on

To start the unit when off (in standby), slide the **HOLD/⏻/⏪** switch toward **⏻/⏪** until **TASCAM DR-70D** (Start-up Screen) appears on the display.

The Home Screen appears after the unit starts up.



Start-up Screen



Home Screen

CAUTION

When the unit is started up for the first time (or when the built-in clock is reset after being left unused without batteries), the **DATE/TIME** screen appears before the Start-up Screen so you can adjust the date and time. (See "Setting the date and time" on page 14.)

Turning the unit off (putting it in standby)

When on, slide the **HOLD/⏻/⏪** switch toward **⏻/⏪** until **LINEAR PCM RECORDER** appears on the display.

The unit turns off (enters standby) after it completes its shutdown process.

CAUTION

Always use the **⏻/⏪** button to turn the unit off (put it in standby).

Do not remove the batteries, disconnect the power cable when using a TASCAM PS-P515U AC adapter (sold separately) or disconnect the USB cable if using USB bus power while the unit is operating. If you do so, recording data and settings, for example, will all be lost. Lost data and settings cannot be restored.

Resume function

This unit has a resume function. When turned on, the unit locates to the position (time) where it was when turned off previously.

After turning the unit on, press the **2/▶** button to resume playback from the file position (time) from when the unit was shut down (put into standby).

NOTE

The required data for this function is stored in the SD card. The resume function will not work if the card is changed or formatted.

3 – Preparation

Setting the date and time

Using its internal clock, this unit adds the date and time to files when they are recorded.

1. Press the **MENU** button to open the MENU screen.

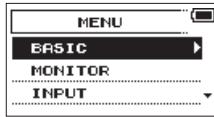

2. Turn the **DATA** dial to select **OTHERS**, and press the **DATA** dial.

The **OTHERS** screen opens.

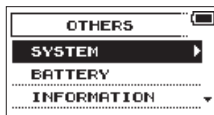

3. Turn the **DATA** dial to select **DATE/TIME**, and press the **DATA** dial.

The **DATE/TIME** screen opens.

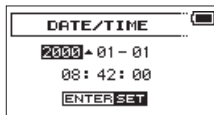

4. Use the **DATA** dial or the **4/|◀◀** and **3/▶▶|** buttons to move the cursor (highlighted area), and turn the **DATA** dial to change the value.
5. Press the **MENU** button to confirm the setting and return to the **OTHERS** screen.

NOTE

You can set the unit to automatically add the date set here to file names. (See "Setting the file name format" on page 35.)

CAUTION

The date and time setting can only be maintained for a few minutes if the battery power becomes low and the unit is not powered by a TASCAM PS-P515U AC adapter (sold separately) or USB bus power.

When using batteries, replace them before they completely lose power.

Inserting and removing SD cards

Inserting a card

1. Open the front cover on the front of the unit.
2. Insert an SD card as shown in the illustration until it clicks into place.

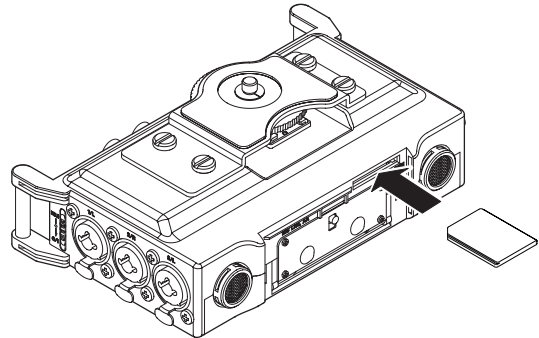

Removing a card

1. Open the front cover on the front of the unit.
2. Press the SD card in gently and then release it to allow it to come out.

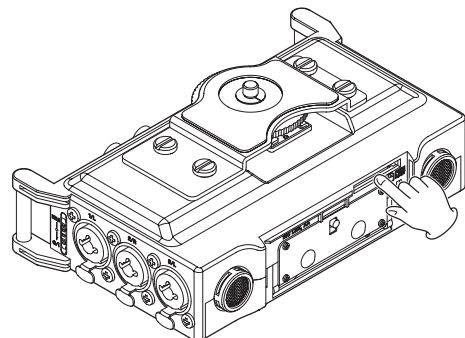

CAUTION

- Do not remove the SD card from the unit during recording, playback or at other times when it is being accessed.
- Do not remove the SD card from the unit when it is connected to a computer by USB.
- SD cards that meet SD, SDHC or SDXC standards can be used with this unit.
- A list of SD cards that have been confirmed to work with this unit can be found on the TEAC Global Site (<http://teac-global.com/>).

SD card write protection switches

SD cards have protect switches that prevent writing new data to them.

If you slide the protect switch to the LOCK position, file recording and editing is not possible. Move the switch to the unlocked position in order to record, erase and otherwise edit data on the card.

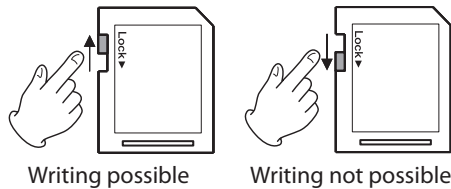

Preparing an SD card for use

In order to use an SD card in this unit, you must format it first.

1. Confirm that an SD card is loaded and turn the unit on.
2. A message like one of the following appears when a new card or a card formatted by another device is installed in the unit.

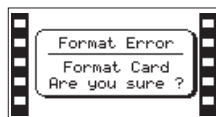

SD/SDHC card

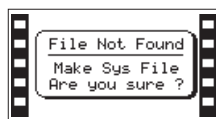

SDXC card

3. Press the **DATA** dial to start formatting.

CAUTION

Formatting a card erases all the data on it.

4. When formatting ends, the Home Screen opens. You can also reformat a card in this unit at any time.

CAUTION

When formatting a card, the unit should be operating on AC power supplied by a TASCAM PS-P515U adapter (sold separately), USB bus power from a computer or batteries with sufficient remaining power.

Connecting monitoring equipment

Connect an external stereo mic to the **EXT IN 1/2** jack on the right side of the unit.

To listen with headphones, connect them to the **PHONES** jack.

To listen with an external monitoring system (powered monitor speakers or an amplifier and speakers), connect it to the **OUT/LINE OUT** jack.

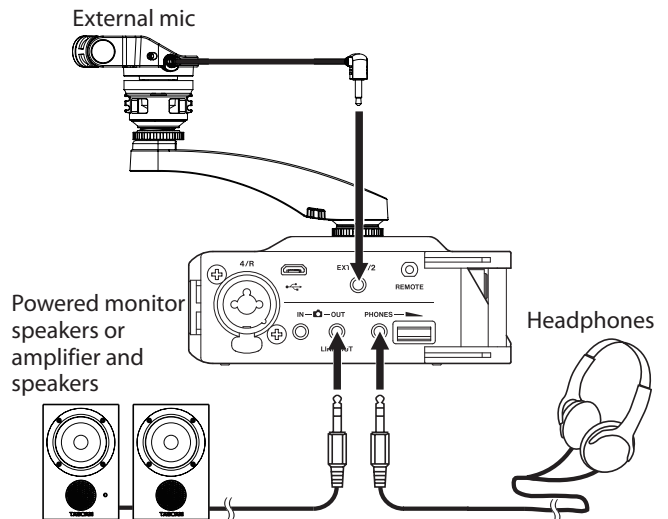

Monitoring

You can monitor the input signals when the unit is stopped using headphones, for example. Moreover, by connecting this unit's **IN** jack with the camera line output, you can check the sound being recorded by the camera.

Selecting the monitored signal

1. Press the **MENU** button to open the MENU screen.
2. Turn the **DATA** dial to select **MONITOR**, and press the **DATA** dial.
The **MONITOR SETTING** screen opens.
3. Turn the **DATA** dial to select **MONITOR SEL**, and press the **DATA** dial.
4. Turn the **DATA** dial to select the sound to monitor, and press the **DATA** dial.

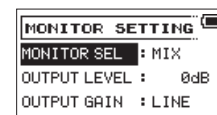

Options

CAM: **IN** jack sound input

MIX (default): Mix of all inputs

5. When finished selecting the monitoring signal, press the **1/■** button to return to the Home Screen.

NOTE

- You can also press and hold the **DATA** dial when stopped to switch the signal monitored.
- When **CAM** is selected, you can monitor the input sound through the **PHONES** jack, but the level meters will show the input sound according to the current recording mode.

3 – Preparation

Setting the output gain

1. Press the **MENU** button to open the MENU screen.
2. Turn the **DATA** dial to select **MONITOR**, and press the **DATA** dial.
The **MONITOR SETTING** screen opens.
3. Turn the **DATA** dial to select **OUTPUT GAIN**, and press the **DATA** dial.
4. Turn the **DATA** dial to select the **OUT** or the **LINE OUT** jack, and press the **DATA** dial.



Options

LINE (default): Set the output gain for output to an external monitoring system (powered monitor speakers or amplifier and speakers)

CAM: Set the output gain for output to a camera

5. When finished setting the output gain, press the **1/■** button to return to the Home Screen.

Adjusting the playback volume

Use the **PHONES** volume control to adjust the volume output from the **PHONES** jack. Use the **OUTPUT LEVEL** item on the **MONITOR SETTING** screen to adjust the volume output from the **OUT/LINE OUT** jack.

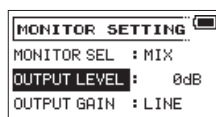
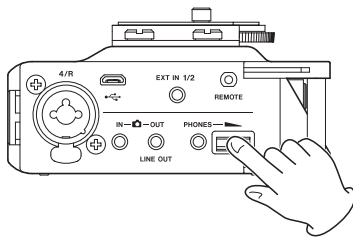

Camera connection and attachment

In order to output the sound from this unit to a DSLR camera and monitor sound from the camera with this unit, you must connect them with commercially-available 3.5mm stereo mini plug cables.

1. Press the **MENU** button to open the MENU screen.
2. Turn the **DATA** dial to select **MONITOR**, and press the **DATA** dial.
The **MONITOR SETTING** screen opens.
3. Turn the **DATA** dial to select **OUTPUT GAIN**, and press the **DATA** dial.
4. Turn the **DATA** dial to select **CAM**, and press the **DATA** dial.



Options: **LINE** (default), **CAM**

5. If you want to record audio from this unit with a camera, connect the **OUT** jack on the right side of this unit with the external mic input on the camera.

If you want to input audio from the camera and monitor it with this unit, connect the **IN** jack on the right side of this unit with the audio output jack on the camera.

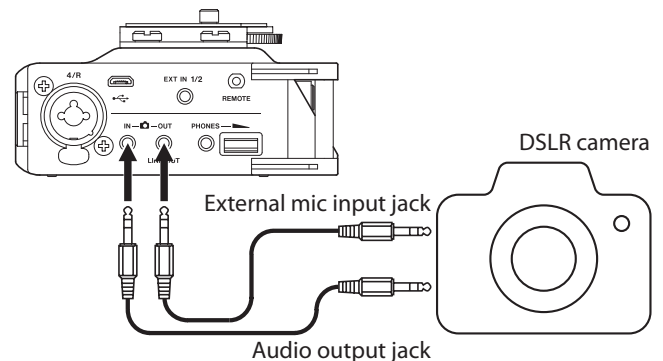

NOTE

Refer to the camera's operation manual to identify this connector on the camera.

6. Use the **OUTPUT LEVEL** item on the **MONITOR SETTING** screen to adjust the volume output to the camera.

NOTE

If the volume is still too low even if you set the **OUTPUT LEVEL** item on the **MONITOR SETTING** screen to its maximum value, set the **OUTPUT GAIN** item on the **MONITOR SETTING** screen to **LINE** and then adjust the volume.

7. To mount the camera on this unit, use the camera attachment screw on the top of the unit.

Setting the inputs

Recording with the built-in stereo mic

Point the built-in stereo mic at the sound source and place the unit in a stable location where there is little vibration.

Connecting microphones

Connect microphones to this unit's **1/L**, **2/R**, **3/L** and/or **4/R** connectors.

Point the mics at the sound source and place the unit in a stable location where there is little vibration.

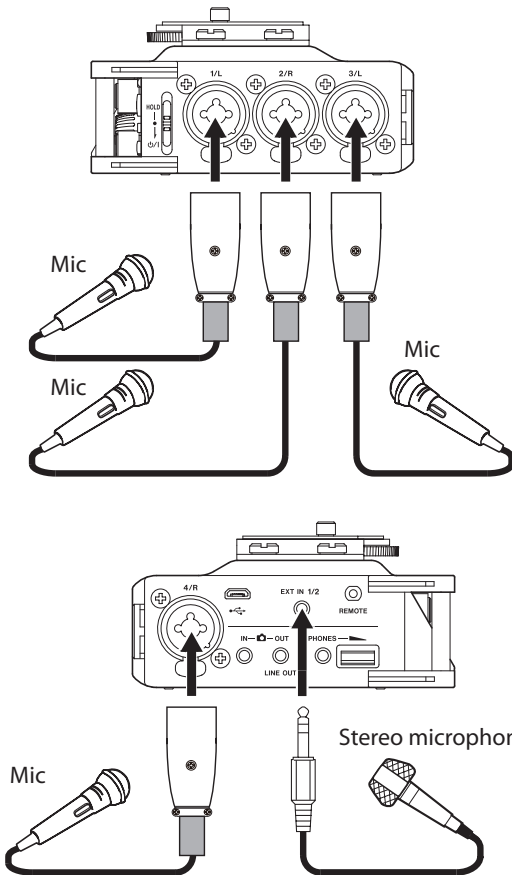

Recording an external device (LINE IN)

Use stereo plug cables to connect to the output of an external audio device.

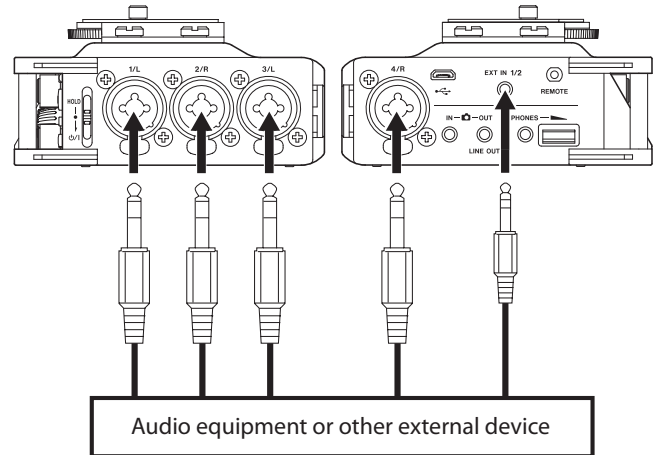

CAUTION

- Reduce the output level of the external audio device if the input sound is distorted even after adjusting the input gain level of the unit.
- Controlling the gain level might not be possible if an external audio device with a fixed output line level is connected and overloads might occur because of excessively loud input signals. In such cases, use the headphone jack or other level-controllable output for connection to the unit.

Using the top panel accessory shoe

To use the accessory shoe on the top panel, remove the DSLR attachment bracket.

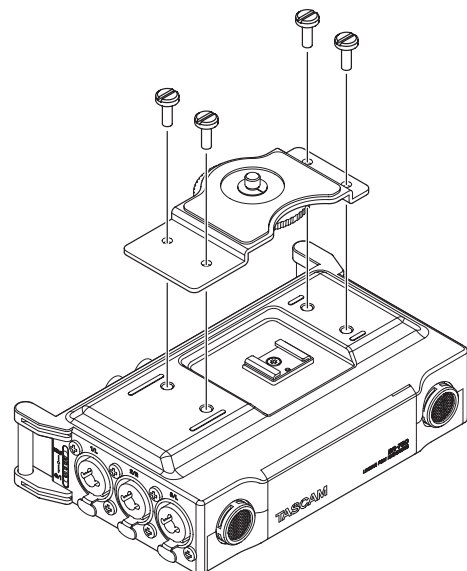

You can attach the included camera attachment bracket screw hole covers to the screw holes.

4 – Recording

This unit can record sound from external microphones and external audio devices, including CD players.

The unit can be set to record audio files in WAV or BWF (44.1/48/96kHz, 16/24-bit) format.

Slate tones added when recording to Broadcast Wave Format (BWF) files can be used as marks with software that supports this format. This unit can record using dual recording, which allows the same input signals to be recorded at two different levels, and 4-channel recording, for example.

Recording formats

You can select the format of files created by this unit.

■ MONO mode

The channels selected for recording will be recorded as mono files.

A file will be made for each channel selected for recording.

■ STEREO mode

Stereo files will be recorded.

Examples:

If only channel 1 is selected for recording, a stereo file with channel 2 silent will be created.

If only channels 1 and 3 are selected for recording, stereo files with channels 2 and 4 silent will be created.

■ MIX mode

The input signals set on the BASIC screen will be recorded as a stereo file.

Even if all four channels are selected for recording, a stereo file will be created.

Setting where to save files

Set the folder where recorded files are saved.

The recorded file will be saved in the currently selected folder. For details, see the SELECT pop-up menu item in “Folder operations” on page 30.

If no setting is made, new files are created in the MUSIC folder.

Setting the channels to record

By default, the channel recording settings are ON. To turn recording for a channel off, set the RECORD item on the BASIC screen to OFF.

1. Press the **MENU** button to open the MENU screen.
2. Turn the **DATA** dial to select **BASIC**, and press the **DATA** dial.
The BASIC screen opens.
3. Press the **1/■**, **2/▶**, **3/▶▶** or **4/◀◀** button to select the recording channel that you want to set.
4. Turn the **DATA** dial to select **RECORD** for the selected channel, and press the **DATA** dial.

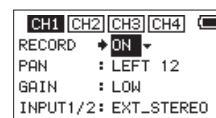

CH1 BASIC screen

5. Turn the **DATA** dial to turn the recording setting ON/OFF.
Options: ON (default), OFF
6. Repeat steps 3 to 5 as necessary to turn recording on/off for each channel.
7. When finished, press the **MENU** button to return to the Home Screen.

Adjusting the input balance

You can set the left-right position of each recording channel with the PAN item on the BASIC screen.

1. Press the **MENU** button to open the MENU screen.
2. Turn the **DATA** dial to select **BASIC**, and press the **DATA** dial.
The BASIC screen opens.
3. Press the **1/■**, **2/▶**, **3/▶▶** or **4/◀◀** button to select the channel for balance adjustment.
4. Turn the **DATA** dial to select **PAN** for the selected channel, and press the **DATA** dial.

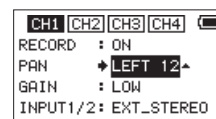

CH1 BASIC screen

5. Turn the **DATA** dial to set the input balance.
Options: LEFT 12 – CENTER – RIGHT 12
6. Repeat steps 3 to 5 as necessary to set the input balance for each channel.
7. When finished adjusting, press the **MENU** button to return to the Home Screen.

Adjusting the input level

Before starting recording, the input level should be adjusted to prevent the recorded sounds or input signals from being distorted due to excessively loud input or from being quieter than the noise level due to excessively low input levels.

In addition to manual adjustment, the unit has a limiter function that you can use as desired. (See “Using the limiter” on page 22.)

TIP

In addition to adjusting the INPUT level, try changing the distance and angle between the microphone and the sound source. The angle and distance of the microphone can also change the character of the recorded sound.

1. Press the **MENU** button to open the MENU screen.
2. Turn the **DATA** dial to select **BASIC**, and press the **DATA** dial.
The BASIC screen opens.
3. Press the **1/■**, **2/▶**, **3/▶▶** or **4/◀◀** button to select the channel for input level adjustment.
4. Turn the **DATA** dial to select **GAIN** for the selected channel, and press the **DATA** dial.

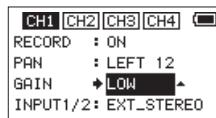

CH1 BASIC screen

NOTE

*To change the channel being set, turn the data dial or press the **1/■**, **2/▶**, **3/▶▶** or **4/◀◀** button to move to a different channel screen.*

5. Turn the **DATA** dial to set the mic input gain.
Options: LOW (default), MID, HIGH, HI+PLUS

NOTE

The input gain is different for the LOW, MID, HIGH and HI+PLUS settings. Make a selection according to the loudness of the input.

If you are not sure which setting to use, try LOW first. If the input level is too low even after adjustment, return to the INPUT screen and set it to MID.

If the level is still too low, set the GAIN to HIGH or HI+PLUS and then adjust the level.

6. When finished adjusting, press the **MENU** button to return to the Home Screen.

7. Use the **1/L**, **2/R**, **3/L** and **4/R** knobs on the back of the unit to adjust the input levels.

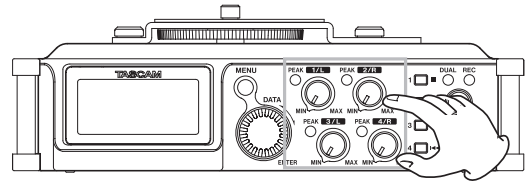

If an input level is too high, the **PEAK** indicator to the left of the knob will light red.

The level meters have a ▼ mark as a guide at –16dB.

Set input level so that level changes occur near this mark without causing **PEAK** indicators to light red.

CAUTION

These also light if distortion occurs in the analog circuitry during mic input.

They will not light, however, if distortion occurs in the analog circuitry during line input.

NOTE

*To monitor the sound while adjusting the input levels or recording, connect headphones to the **PHONES** jack.*

*Use the **PHONES** jack volume control to adjust the monitoring level.*

8. Repeat steps 3 to 6 as necessary to set the mic input gain for each channel.

4 – Recording

Setting the recording input source

Use the **INPUT 1/2** and **INPUT 3/4** items on the **BASIC** screen to set the recording input source.

1. Press the **MENU** button to open the **MENU** screen.
2. Turn the **DATA** dial to select **BASIC**, and press the **DATA** dial.

The **BASIC** screen opens.

3. Turn the **DATA** dial to select **INPUT 1/2** or **INPUT 3/4** for the selected channel, and press the **DATA** dial.

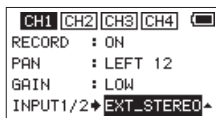

CH1 BASIC screen

4. Turn the **DATA** dial to select the input source for the recording channel.

Item	Option	Meaning
INPUT 1/2	EXT STEREO (default)	Input from the EXT 1/2 jack
	EXT POWER	Input from the EXT 1/2 jack (plug-in power on)
	XLR/TRS	Input from the 1/L and 2/R jacks
INPUT 3/4	MIC (default)	Input from the built-in mic
	XLR/TRS	Input from the 3/L and 4/R jacks

5. When finished adjusting, press the **MENU** button to return to the Home Screen.

Using plug-in power

The plug-in power function can be turned on when an external mic that requires it is connected to the **EXT IN 1/2** jack.

1. Press the **MENU** button to open the **MENU** screen.
2. Turn the **DATA** dial to select **BASIC**, and press the **DATA** dial.

The **BASIC** screen opens.

3. Press the **1/■** or **2/▶** button to show the **INPUT 1/2** item.

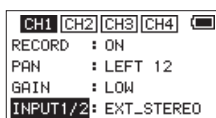

4. Turn the **DATA** dial to select **INPUT 1/2**, and press the **DATA** dial.

The cursor moves to the setting item.

5. Turn the **DATA** dial to set it to **EXT_POWER**, and press the **DATA** dial.

This turns plug-in power on. A different setting item can now be selected.

6. When finished, press the **MENU** button to return to the Home Screen.

CAUTION

- When connecting a dynamic mic or external mic that has its own battery, set **INPUT 1/2** to **EXT_STEREO**. Setting it to **EXT_POWER** could damage such microphones.
- Use headphones to monitor when you are recording with a microphone. If you use speakers for monitoring, the sound output from the speakers could be picked up by the mic, resulting in its unwanted recording or feedback noise.

Setting the input gain

Set the **INPUT GAIN** item on the **INPUT** screen according to the type of equipment connected.

1. Press the **MENU** button to open the **MENU** screen.
 2. Turn the **DATA** dial to select **INPUT**, and press the **DATA** dial.
- The **INPUT** screen opens.
3. Press the **1/■**, **2/▶**, **3/▶▶** or **4/◀◀** button to select the channel for input gain setting.
 4. Turn the **DATA** dial to select **INPUT GAIN** for the selected channel, and press the **DATA** dial.

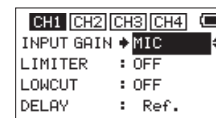

CH1 INPUT screen

5. Turn the **DATA** dial to set the input gain.

Options

LINE:

Use this setting when connecting line output jacks of external devices to the analog inputs of this recorder.

MIC (default):

Use this setting when connecting mics to the recorder.

MIC+PHANTOM:

Use this setting when connecting condenser mics that require phantom power (24V or 48V) to the recorder.

If the **INPUT1/2** or **INPUT3/4** item on the **BASIC** screen for the channel being set is set to **XLR/TRS**, when you set it to **MIC+PHANTOM**, a pop-up message appears confirming that you want to turn phantom power on. (See "Using phantom power" on page 21.)

Use the **MIC SETTING** screen to set the voltage to 24V or 48V. (See "Setting the phantom power voltage" on page 21.)

6. When finished, press the **MENU** button to return to the Home Screen.

CAUTION

Depending on this setting, the input level setting range changes. For this reason, the input level might change greatly when this setting is changed, so turn the output level all the way down before changing it.

Using phantom power

When stopped (and the INPUT1/2 or INPUT3/4 item is set to XLR/TRS on the BASIC screen for the channel being set), if you set the INPUT GAIN item on the INPUT screen to MIC+PHANTOM, a pop-up message appears confirming that you want to turn phantom power on.



When the confirmation pop-up message opens, press the **DATA** dial to turn phantom power (24V or 48V) on for the **1/L**, **2/R**, **3/L** and **4/R** connectors and supply it to the connected mics.

Use the MIC SETTING screen to set the voltage to 24V or 48V. (See “Setting the phantom power voltage” on page 21.)

NOTE

Battery power will be consumed faster when set to 48V than when set to 24V.

CAUTION

- *Confirm that phantom power is OFF before connecting a line level device to the 1/L, 2/R, 3/L or 4/R connector. If you connect a line level device while phantom power is being supplied, that device and this unit could be damaged.*
- *Before connecting a condenser mic to or disconnecting one from the 1/L, 2/R, 3/L or 4/R connector, confirm that the phantom power for that jack is OFF. If you connect or disconnect a mic while phantom power is being supplied, that mic and this unit could be damaged.*
- *Turn phantom power ON only when using a condenser microphone that requires phantom power.*
- *Supplying phantom power to some ribbon mics will break them. If you are unsure, do not supply phantom power to a ribbon mic.*
- *When using USB bus power, the unit might not be able to supply phantom power depending on the computer. In this case, use a TASCAM PS-P515U AC adapter (sold separately).*
- *Some condenser microphones will not operate when phantom power is set to 24V.*
- *Do not connect or disconnect the power cable connected to the USB port when using phantom power. Doing so could interrupt the power to the unit even if it has batteries, resulting in the damage or loss of recording data.*

Setting the phantom power voltage

Use the PHANTOM VOLT item on the MIC SETTING screen to set the power voltage supplied when a microphone that requires phantom power is connected.

1. Press the **MENU** button to open the MENU screen.
2. Turn the **DATA** dial to select **MIC**, and press the **DATA** dial. The MIC SETTING screen opens.
3. Turn the **DATA** dial to select **PHANTOM VOLT**, and press the **DATA** dial.

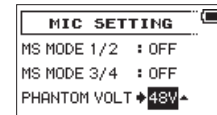

4. Turn the **DATA** dial to set the voltage of phantom power when it is supplied.
Options: 24V, 48V (default)

NOTE

Battery power will be consumed faster when set to 48V than when set to 24V.

5. When finished, press the **1/■** button to return to the Home Screen.

4 – Recording

Using the limiter

When the limiter is on, the input gain will adjust automatically in response to the input level, setting the recording level so that distortion does not occur even when loud sounds are input.

1. Press the **MENU** button to open the MENU screen.
2. Turn the **DATA** dial to select **INPUT**, and press the **DATA** dial.

The INPUT screen opens.

3. Press the **1/■**, **2/▶**, **3/▶▶** or **4/◀◀** button to select a channel to use the limiter on.
4. Turn the **DATA** dial to select the **LIMITER** for the selected channel, and press the **DATA** dial.

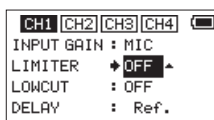

CH1 INPUT screen

5. Turn the **DATA** dial to set the limiter.

Options	Meaning
OFF (default)	Limiter off
MONO	Limiter on only for selected channel
LINK	Limiter on for both selected and linked channels

6. Repeat steps 3 to 5 as necessary to set the limiter for each channel.
7. When finished, press the **MENU** button to return to the Home Screen.

CAUTION

Distortion might occur if the input sound is too loud even when the limiter is on. In such a case, lower the input level or increase the distance between the unit and the sound source.

NOTE

- The **LIMITER** icon appears on the recording screen when the limiter is on for any channel (when set to **MONO** or **LINK**).
- When you switch the **CH1 (CH2)/CH3 (CH4)** limiter setting between **MONO** and **LINK**, the setting of the other channel will also be changed, so a confirmation pop-up message will appear.



Pop-up message when changing between **MONO** and **LINK**

- When set to **MONO**, the limiter only affects the channel that has excessive input. When set to **LINK**, the limiter affects both channels in the pair when either has excessive input.

Using the low-cut filter

The low-cut filter can reduce noise from, for example, air-conditioners and projectors as well as wind.

1. Press the **MENU** button to open the MENU screen.
2. Turn the **DATA** dial to select **INPUT**, and press the **DATA** dial.

The INPUT screen opens.

3. Press the **1/■**, **2/▶**, **3/▶▶** or **4/◀◀** buttons to select the channel to use the low-cut filter on.
4. Turn the **DATA** dial to select **LOW CUT** for the selected channel, and press the **DATA** dial.

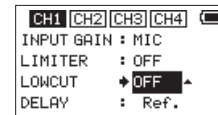

CH1 INPUT screen

5. Turn the **DATA** dial to select the cut off frequency of the low cut filter.

Options: OFF (default), 40Hz, 80Hz, 120Hz, 180HZ, 220Hz

6. Repeat steps 3 to 5 as necessary to set the low-cut filter for each channel.
7. When finished, press the **MENU** button to return to the Home Screen.

Compensating for mic distances

This unit can compensate for delays that result from differences in distance between the built-in and external mics, as well as between external mics.

1. Press the **MENU** button to open the MENU screen.
2. Turn the **DATA** dial to select **INPUT**, and press the **DATA** dial.

The **INPUT** screen opens.

3. Press the **2/▶**, **3/▶▶** or **4/◀◀** button to select the channel to compensate for distance relative to CH1.
4. Turn the **DATA** dial to select **DELAY** for the selected channel, and press the **DATA** dial.

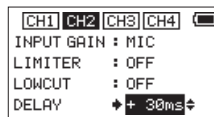

5. Turn the **DATA** dial to set this value according to the distance of the connected mic.
Range: 0ms (default) to ±150ms (in 1ms increments)
6. When finished, press the **MENU** button to return to the Home Screen.

Setting the phase of each channel

You can set the input phase.

1. Press the **MENU** button to open the MENU screen.
2. Turn the **DATA** dial to select **INPUT**, and press the **DATA** dial.
The **INPUT** screen opens.
3. Press the **1/■**, **2/▶**, **3/▶▶** or **4/◀◀** button to select the channel for phase adjustment.
4. Turn the **DATA** dial to select **PHASE** for the selected channel, and press the **DATA** dial.

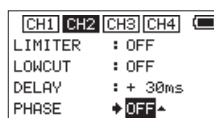

5. Turn the **DATA** dial to set the phase of the selected channel.
Options: OFF (default, normal phase), ON (reversed phase)
6. Repeat steps 3 to 5 as necessary to set the phase for each channel.
7. When finished adjusting, press the **MENU** button to return to the Home Screen.

This shows the file type, format and sampling frequency used for recordings.

Set the audio file type that you want to record before you start recording.

1. Press the **MENU** button to open the MENU screen.
2. Turn the **DATA** dial to select **RECORD**, and press the **DATA** dial.
The **RECORD SETTING** screen opens.
3. Turn the **DATA** dial to select **FILE TYPE**, and press the **DATA** dial.

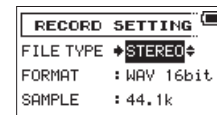

4. Turn the **DATA** dial to select the recording file type.

Options	Meaning
MONO	Record in mono
STEREO (default)	Record in stereo
2MIX	Record mixed signal in stereo

5. Press the **DATA** dial to enable selection of other items.
6. Turn the **DATA** dial to select **FORMAT**, and press the **DATA** dial.
Set the file format.
Turn the **DATA** dial to select one of the following options.
Options: BWF 16bit, BWF 24bit, WAV 16bit (default), WAV 24bit

NOTE

BWF is a format created for broadcasting that has the same sound quality as the standard WAV format. It also uses the same ".wav" file extension as WAV files. In this document, we distinguish these file types by using the "BWF" for WAV files that support BWF features and "WAV" for all other WAV files.

7. Press the **DATA** dial or **3/▶▶** button to enable selection of other items.
8. Turn the **DATA** dial to select **SAMPLE**, and press the **DATA** dial.
Set the sampling frequency.
Turn the **DATA** dial to select one of the following options.
Options: 44.1k (default), 48k, 96k
9. Press the **DATA** dial or **4/◀◀** button to move the cursor back to the setting item.
10. When finished, press the **1/■** button to return to the Home Screen.

4 – Recording

Recording (MONO/STEREO/2MIX)

Starting recording

1. Press the **record** (●) button to start ordinary recording.



When recording starts, the REC indicator lights continuously, and the display shows the elapsed recording time and the remaining recording time.

2. Press the **record** (●) or **1/** button to stop recording.

NOTE

To avoid recording the noise of pressing the record (●) button, recording starts 0.3 second after the button is pressed.

File names when recording in MONO

When mono recording, a file will be made for each channel. The file names will be as follows.

TASCAM_0001S1.WAV

① ② ③ ④

- ①: Set with the **WORD** item on the **FILE NAME** screen
- ②: Recording file project number
- ③: Source file
- ④: Assigned channel

File names when recording in STEREO/2MIX

When stereo recording, a file will be made for the 1/2 or 3/4 channel pair.

The file names will be as follows.

TASCAM_0002S12.WAV

① ② ③ ④

- ①: Set with the **WORD** item on the **FILE NAME** screen
- ②: Recording file project number
- ③: Source file
- ④: Assigned channels

Creating a new file without interrupting recording (track incrementing)

You can manually create a new file without pausing recording and set the unit to automatically do the same when the file size reaches 2 GB.

Manual track incrementation during recording

You can manually split a recording by creating a new file.

1. Press the **3/** button while recording to create a new file.

NOTE

When new files are created, incremental numbers are added to the end of each file name.

CAUTION

- A new file cannot be created if the total number of folders and files would exceed 5000.
- Files shorter than two seconds cannot be created. Moreover, if the sampling frequency is 96 kHz, files shorter than four seconds cannot be created.
- If the name of a newly created file would be the same as that of an existing file, the number will be incremented until the new file has a unique name.

Automatic track incrementation during recording

Without pausing recording, a new file can be created automatically during recording when the file size reaches 2 GB.

CAUTION

A new file cannot be created if the total number of folders and files would exceed 5000.

Simultaneously recording two files at different input levels (DUAL REC)

This recorder can simultaneously record a second recording at a different input level along with the regular recording. For example, when recording with microphones, you can make an ordinary recording with the input level set as high as possible and simultaneously record at a slightly lower input level for safety.

Two recorded files (one with higher input level and one with lower input level) are saved individually.

NOTE

Make the input level setting for the ordinary recording in the usual manner. (See “Adjusting the input level” on page 19.), (See “Setting the input gain” on page 20.)

Enabling dual recording

1. Press the **MENU** button to open the MENU screen.
2. Turn the **DATA** dial to select **RECORD**, and press the **DATA** dial.

The **RECORD SETTING** screen opens.

3. Turn the **DATA** dial to select **DUAL REC**, and press the **DATA** dial.

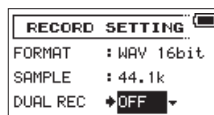

4. Turn the **DATA** dial to set the input gain level of the other recording.
Options: OFF (default), -1dB to -12dB (in -1dB increments)

NOTE

This function cannot be enabled if more than two channels are selected for recording or if the two selected channels prevent the recording of a stereo pair (for example, CH1 and CH3).

5. Press the **DATA** dial or **4/I◀◀** button to enable selection of other items.
6. When finished, press the **1/■** button to return to the Home Screen.

Starting dual recording

Press the **record (●)** button to start dual recording.

During dual recording, the recording screen appears as follows.



In the input source display area of the recording screen, the input levels of the current input source and the dual recording are shown.

Dual recording file names

Dual recording will create two files simultaneously.

The name of the second file created by dual recording has “-XX” added to the file name of the ordinary recording.

“-XX” shows the amount that the input level has been lowered.

TASCAM_0003S12.WAV

① ② ③ ④

TASCAM_0003SD12-05.WAV

① ② ③ ⑤ ④ ⑥

- ①: Set with the **WORD** item on the **FILE NAME** screen
- ②: Recording file project number
- ③: S is the source file
- ④: Assigned channels (“12” is CH1 and CH2 and “34” is CH3 and CH4)
- ⑤: D (dual recording file with lower level)
- ⑥: This dual recording file was recorded with the input level set to -5dB. (This would be “-06” if recorded at -6dB or “-10” if recorded at -10dB, for example.)

4 – Recording

Using the auto tone function

The function can be used to automatically add a tone when beginning and ending recordings.

By connecting the **OUT** jack on the right side of the unit to the camera audio input jack, the same tone signal can be recorded to both files. These tones can be used as guides when aligning files in video editing software.

For details about how to connect a DSLR camera, see “Camera connection and attachment” on page 16.

NOTE

*If the volume is still too low even if you set the **OUTPUT LEVEL** item on the **MONITOR SETTING** screen to its maximum value, set the **OUTPUT GAIN** item on the **MONITOR SETTING** screen to **LINE** and then adjust the volume.*

Setting the auto tone function

1. Press the **MENU** button to open the **MENU** screen.
2. Turn the **DATA** dial to select **SLATE**, and press the **DATA** dial.
The **SLATE SETTING** screen appears.
3. Turn the **DATA** dial to select **AUTO TONE**, and press the **DATA** dial.

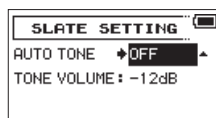

4. Turn the **DATA** dial to select the tone insertion points.
Options: **OFF** (default), **HEAD** (start of recording only), **HEAD+TAIL** (start and end of recording)
5. When finished, press the **1/■** button to return to the Home Screen.

Set the volume of auto and slate tones

You can adjust the volume setting of auto and slate tones.

1. Press the **MENU** button to open the **MENU** screen.
2. Turn the **DATA** dial to select **SLATE**, and press the **DATA** dial.
The **SLATE SETTING** screen appears.
3. Turn the **DATA** dial to select **TONE VOLUME**, and press the **DATA** dial.

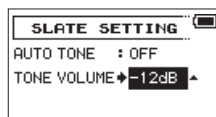

4. Turn the **DATA** dial to set the tone volume.
Options: **-12dB** (default), **-18dB**, **-24dB**, **-30dB**, **-36dB**
5. When finished, press the **1/■** button to return to the Home Screen.

Recording slate tones

During recording, press the **SLATE** button to add a slate tone to the recorded file at the point you want.

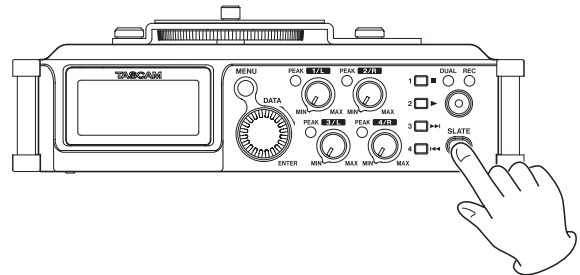

For details about how to connect a DSLR camera, see “Camera connection and attachment” on page 16.

NOTE

*The **SLATE** button must be pressed and held briefly to insert a slate tone. This delay is to prevent accidental operation.*

Moving to slate tone positions

You can move to slate tone positions in the currently selected file when stopped or playing back.

You can use them like shortcuts to the beginning of songs, for example.

1. Turn the **DATA** dial during playback or when stopped.
Turn the **DATA** dial right to move to the next slate tone position and turn it left to move to the previous slate tone position.

NOTE

*If no slate tone has been inserted later in the current file, turning the **DATA** dial right will move to the beginning of the next file.*

*If no slate tone has been inserted earlier in the current file, turning the **DATA** dial left will move to the beginning of the current file.*

Using mid-side microphones

This unit has a mid-side decoder and can be used to record with a mid-side mic and playback such recordings.

1. Connect a mid-side mic to the **1/L** and **2/R** or **3/L** and **4/R** jacks.
Connect the mid mic to the **1/L** or **3/L** jack and the the side mic to the **2/R** or **4/R** jack.
If the mid and side are connected in reverse, proper recording will not be possible.
2. Press the **MENU** button to open the MENU screen.
3. Turn the **DATA** dial to select **MIC**, and press the **DATA** dial.
The **MIC SETTING** screen opens.
4. Turn the **DATA** dial to select **MS MODE 1/2** or **MS MODE 3/4**, and press the **DATA** dial.

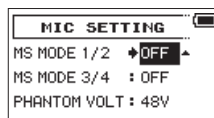

5. Turn the **DATA** dial to set the decoding mode when using a mid-side mic.

Options	Meaning
OFF (default)	Record in ordinary stereo mode.
REC	Use to decode while recording. Playback is conducted without decoding.
PLAY	Record mid-side mic output without decoding for decoding later. Use this mode to monitor when recording with a mid-side mic. Use this also when playing back mid-side files that were recorded without decoding.

6. When finished, press the **1/■** button to return to the Home Screen.
7. When set to **REC**, the decoded signal will be recorded.
When set to **PLAY**, the signal will be decoded as it is played back.

4 – Recording

Recording duration

The table below shows maximum recording times (in hours: minutes) by file format on SD/SDHC/SDXC cards of different capacities.

File format (recording setting)		SD/SDHC/SDXC card capacity			
		1 GB	4 GB	32 GB	128 GB
WAV/BWF 16-bit (STEREO)	44.1 kHz	1:41	6:44	53:52	201:35
	48 kHz	1:33	6:12	49:36	185:13
	96 kHz	00:46	3:06	24:48	92:36
WAV/BWF 24-bit (STEREO)	44.1 kHz	1:07	4:30	35:44	134:24
	48 kHz	1:02	4:08	33:04	123:28
	96 kHz	00:31	2:04	16:32	61:44

- The recording times shown above are estimates. They might differ depending on the SD/SDHC/SDXC card in use.
- The recording times shown above are not continuous recording times, but rather they are the total possible recording times for the SD/SDHC/SDXC card.
- When using MONO (single channel) recording, the maximum recording times will be about twice the figures above.
- When using 4-channel recording, the maximum recording time will be about half the figures above.

5 – Working with Files and Folders (BROWSE screen)

On the **BROWSE** screen, you can view the contents of the **MUSIC** Folder, which contains the audio files on the SD card that you can use with the unit.

TIP

*If you connect the unit with a computer by USB, or mount the SD card on a computer using a card reader or other input, you can change the folder structure within the **MUSIC** Folder and erase files from the computer as you would the contents of a hard drive. Furthermore, you can change file names from the computer.*

To open the **BROWSE** screen, press the **MENU** button to open the **MENU** screen. Then, turn the **DATA** dial to select **BROWSE** and press the **DATA** dial.

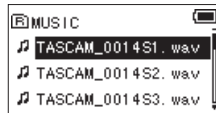

The contents of the folder that contains the file that was selected on the Home Screen before the **BROWSE** screen was opened appears on the display.

BROWSE screen navigation

On the **BROWSE** screen, folders and music files appear in a list much like they would appear on a computer.

This unit can make only two levels of folders.

- Turn the **DATA** dial to select files and folders.
- When a folder is selected, press the **3/▶▶▶** button to show the contents of that folder.
- When a file or folder is selected, press the **4/◀◀◀** button to close the currently open folder and show the level above.
- When a file or folder is selected, press the **DATA** dial to open a pop-up menu.
- When a file is selected, press the **2/▶** button to return to the Home Screen and play the file.

The folder that contains this file becomes the current folder, and new recorded files will be saved in it. This folder also becomes the playback area.

- When a file is selected, press the **3/▶▶▶** button to return to the Home Screen and load that file.

The folder that contains this file becomes the current folder, and new recorded files will be saved in it. This folder also becomes the playback area.

- When a folder is selected, press the **2/▶** button to return to the Home Screen. The first file in the folder (file shown at the top of the list) will be played.

This folder becomes the current folder, and new recorded files will be saved in it. This folder also becomes the playback area.

Icons on the BROWSE screen

The meanings of icons that appear on the **BROWSE** screen are as follows.

■ MUSIC Folder (📁)

The **MUSIC** Folder is shown at the highest level when the root is open on the **BROWSE** screen.

■ Audio file (🎵)

This 🎵 icon appears before the names of music files.

■ Plain folder (📁)

This icon shows folders that contain subfolders.

■ Plain folder (📁)

This icon shows folders that do not contain subfolders.

■ Open folder (📁)

The contents of the folder marked with this icon currently appear on this screen.

■ New folder (📁)

Use this to create a new folder.

File operations

Select the desired audio file on the **BROWSE** screen and press the **DATA** dial to open the pop-up menu that is shown below.



Turn the **DATA** dial to select the desired item, and press the **DATA** dial to make the unit execute one of the following operations.

■ INFO

Information (date/time, size) about the selected file appears.

Press the **DATA** dial again or press the **1/■** button to return to the **BROWSE** screen.

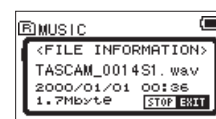

■ DELETE

A message appears to confirm that you want to delete the file.

Press the **DATA** dial to delete the file or the **1/■** button to cancel deletion.

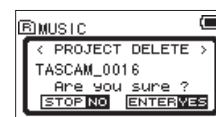

CAUTION

In addition to the currently selected file, this will delete other files with the same base number.

■ CANCEL

Cancel deletion of the selected file and close the pop-up menu.

5 – Working with Files and Folders (BROWSE screen)

Folder operations

Select the desired folder on the **BROWSE** screen and press the **DATA** dial to open the pop-up menu shown below.

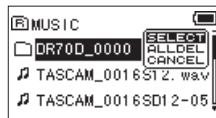

Turn the **DATA** dial to select the desired item, and press the **DATA** dial to make the unit execute one of the following operations.

■ SELECT

Returns to the Home Screen and selects the first file in the folder. This folder also becomes the playback area. When recording, files are created in this folder.

■ ALL DEL

A pop-up message appears to confirm that you want to delete all the files in the selected folder at once.

Press the **DATA** dial to delete the files or the **1/■** button to cancel deletion.

NOTE

You cannot delete read-only files and files that are not recognized by this unit.

■ CANCEL

Cancel the operation with the selected folder and close the pop-up menu.

Creating a new folder

NEW FOLDER appears at the end of each folder's file list.



Select **NEW FOLDER**, and press the **DATA** dial.

A pop-up appears to confirm that you want to create a new folder.



Press the **DATA** dial to create a new folder or press the **1/■** button to cancel. Since this unit supports only two levels of folders, **NEW FOLDER** does not appear in second-level folders.

A newly created folder becomes the current one, and new recorded files are saved in this folder. This folder also becomes the playback area.

Playing recordings

When the Home Screen is open and playback is stopped, press the **2/▶** button to start playback.

NOTE

You can also choose files for playback by name on the BROWSE screen.

Pausing

When the Home Screen is open and a file is playing back, press the **1/■** button to pause playback at the current position.

Press the **2/▶** button again to restart playback from that position.

Stopping

When the Home Screen is open and a track is playing back, press the **1/■** button to pause playback, and press the **1/■** button again to return to the beginning of the file and stop playback.

Searching backward and forward

When the Home Screen is open and a track is playing back or stopped, press and hold the **4/◀◀** or **3/▶▶** button to search the playback track backward or forward.

NOTE

*Press and hold the **4/◀◀** or **3/▶▶** button to accelerate the search speed.*

Selecting files for playback (skipping)

When the Home Screen is open, use the **4/◀◀** and **3/▶▶** buttons to select a file for playback.

If you press the **4/◀◀** button when the playback position is in the middle of a file, it will return to the beginning of that file. If you press the **4/◀◀** button when at the beginning of a file, the playback position will skip to the beginning of the previous file.

Press the **3/▶▶** button when at the beginning or middle of a file to skip to the beginning of the next file.

NOTE

- *The track name, file number and other file information for the currently playing track appear on the display.*
- *The ■ icon appears on the display when playback is stopped at the beginning of a track. The || icon appears when playback is stopped in the middle of a track.*
- *Press the **4/◀◀** or **3/▶▶** button repeatedly to move to the desired file.*

Playing files created with dual recording

Files created with dual recording are added immediately after the files that were created at the normal level.

Play the normally recorded file and press **3/▶▶** to switch to playback of the file recorded at a lower input level.

7 – Connecting with a Computer

By connecting this unit with a computer using the USB cable, you can transfer audio files on the SD card in the unit to a computer, as well as transfer audio files on the computer to the card.

This unit can handle audio files of the following formats.

WAV: 44.1/48/96kHz, 16/24-bit

BWF: 44.1/48/96kHz, 16/24 bit

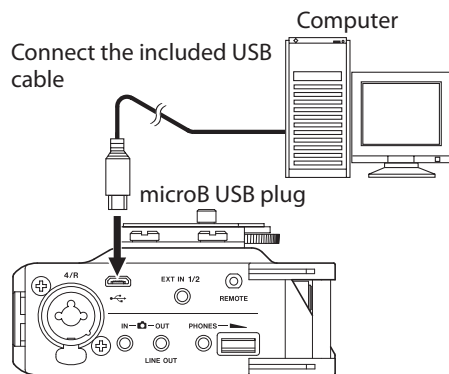

NOTE

- Instead of using USB to connect the unit and a computer, you can also conduct the same operations by removing the SD card from the unit and connecting it directly to a computer that has a built-in SD card slot or by using a card reader.
- Both WAV and BWF files uses the same “.wav” file extension.

CAUTION

- You cannot use this unit's other functions when it is connected to a computer by USB and set to STORAGE.
- The unit should be connected directly with the computer instead of via a USB hub.

The USB SELECT screen appears when the unit is connected by USB and when the unit is turned on if the USB cable is already connected. On this screen, choose between USB bus power supply or USB connection with the computer.

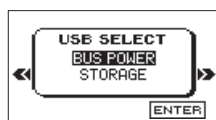

Use the **DATA** dial to select **STORAGE**, and press the **DATA** dial to connect the unit with the computer for data transmission. **USB connected** appears in the display.



Make sure that an SD card is properly inserted in the unit.

NOTE

Power is supplied from the USB port if the USB cable is connected to a unit that contains batteries. (USB bus power prioritized).

This unit appears on the computer as an external drive named “DR-70D” (if the card has been formatted by this unit).

Transferring files to a computer

1. Click the “DR-70D” drive on the computer screen to show the “MUSIC” and “UTILITY” folders.
2. Open the “MUSIC” folder and drag and drop the files that you want to transfer to the computer to the destinations of your choice.

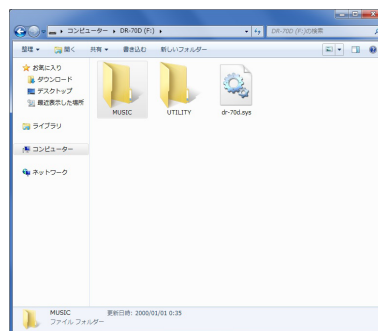

Transferring files from a computer

1. Click the “DR-70D” drive on the computer screen to show the “MUSIC” and “UTILITY” folders.
2. Drag and drop files on the computer that you want to transfer to the unit to the “MUSIC” folder.

TIP

- You can manage the MUSIC folder from the computer.
- You can create subfolders in the MUSIC folder. The unit can use only two levels of folders. The unit cannot recognize subfolders and files on the third level or below.
- If you name subfolders and music tracks, these names will appear on the Home Screen and the BROWSE screen of the unit.

Disconnecting from a computer

Before disconnecting the USB cable, use the proper procedures for your computer to unmount the unit.

The unit turns off (enters standby) after it completes its shutdown process.

See the computer's operation manual for instructions about how to unmount an external device.

8 – Settings and Information

Viewing information

Use the **INFORMATION** screen to view various types of information about the unit.

Follow the procedures below to open the **INFORMATION** screen.

1. Press the **MENU** button to open the **MENU** screen.
2. Turn the **DATA** dial to select **OTHERS**, and press the **DATA** dial to open the **OTHERS** screen.
3. Turn the **DATA** dial to select **INFORMATION**, and press the **DATA** dial.

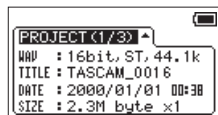

The **PROJECT** page (1/3) of the **INFORMATION** screen is shown.

The **INFORMATION** screen contains the following pages.

4. Turn the **DATA** dial to change the page.

The pages show the following information.

PROJECT (1/3) page:

Shows information about the currently loaded file.

CARD (2/3) page:

Shows the use status of the currently inserted SD card.

SYSTEM (3/3) page:

Shows the unit's system setting information and firmware version.

File information page (PROJECT)

The **PROJECT** (1/3) page shows information about the currently loaded audio file.

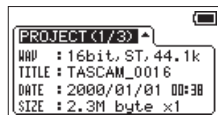

■ WAV/BWF

Shows the audio file type.

For WAV/BWF files, bit depth, stereo/mono and sampling frequency (Hz) are shown.

■ TITLE

Shows the project name.

■ DATE

Shows the date of file creation.

■ SIZE

Shows the file size.

Card information page (CARD)

The **CARD** (2/3) page shows the status of the currently inserted SD card.

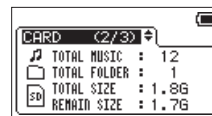

■ TOTAL MUSIC

Shows the number of playable files in the Music Folder.

■ TOTAL FOLDER

Shows the total number of folders in the Music Folder.

■ TOTAL SIZE

Shows the total SD card capacity.

■ REMAIN SIZE/USED SIZE

Shows the amount of unused/used capacity on the SD card.

Press the **4/|◀◀** or **3/▶▶|** button to switch between **REMAIN SIZE** and **USED SIZE**.

System information page

The **SYSTEM** (3/3) page shows information about the unit's system settings and firmware version.

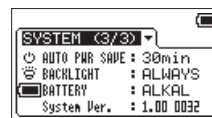

■ AUTO PWR SAVE

Shows the automatic power saving time setting.

■ BACKLIGHT

Shows the automatic backlight OFF setting.

■ BATTERY

Shows the battery type setting.

■ System Ver.

Shows the system firmware version.

8 – Settings and Information

System Settings

From the **SYSTEM** screen, you can change various settings to optimize the device for your use environment and other requirements. You can also initialize the unit and format the SD card.

Follow the procedures below to open the **SYSTEM** screen.

1. Press the **MENU** button to open the **MENU** screen.
2. Turn the **DATA** dial to select **OTHERS**, and press the **DATA** dial to open the **OTHERS** screen.
3. Turn the **DATA** dial to select **SYSTEM**, and press the **DATA** dial.

The **SYSTEM** screen opens.

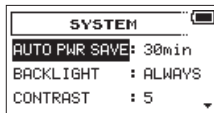

The following settings can be made for the items on the **SYSTEM** screen.

Use the **4/|◀◀** or **3/▶▶|** button or the **DATA** dial to set each item.

Setting the automatic power saving function

Use the **AUTO PWR SAVE** item to set the time before the unit power automatically turns off (enters standby) after the last activity or use.

Options: OFF (unit does not automatically turn off), 3min, 5min, 10min, 30min (default)

Setting the backlight

Use **BACKLIGHT** to set the time until the backlight automatically turns OFF after the last operation when powered by battery.

Options: OFF (unlit), 5sec (default), 10sec, 15sec, 30sec, ALWAYS (always on)

Adjusting the display contrast

Use **CONTRAST** to adjust the display contrast.

Options: 1–20 (default: 5)

Restoring the factory settings

Use the **INITIALIZE** item to restore the various settings of this unit to their factory settings.

1. Turn the **DATA** dial to select **INITIALIZE**, and press the **DATA** dial to highlight Exec.
2. Press the **DATA** dial to open a pop-up confirmation message.

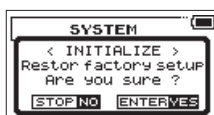

3. Press the **DATA** dial to initialize the unit.
Press the **1/■** button to cancel initialization.

Formatting an SD card

Use the **FORMAT** item to format the SD card.

Formatting erases all music files on the SD card and automatically creates new "MUSIC" and "UTILITY" folders as well as a "dr-70.sys" file.

1. Turn the **DATA** dial to select **FORMAT**, and press the **DATA** dial to highlight Exec.
2. Press the **DATA** dial to open a pop-up confirmation message.



3. Press the **DATA** dial to format the card.
Press the **1/■** button to cancel formatting.

CAUTION

When formatting a card, the unit should be operating on AC power supplied through a TASCAM PS-P515U adapter (sold separately), USB bus power supplied from a computer or batteries with sufficient remaining power.

If the power fails during formatting, the formatting may not occur correctly.

Setting the battery type

Use **BATTERY TYPE** to set the type of batteries being used. This setting is used to show the amount of remaining battery charge and determine if the unit has enough power for normal operation.

1. Press the **MENU** button to open the **MENU** screen.
2. Turn the **DATA** dial to select **OTHERS**, and press the **DATA** dial to open the **OTHERS** screen.
3. Turn the **DATA** dial to select **BATTERY**, and press the **DATA** dial.
The **BATTERY** screen opens.
4. Turn the **DATA** dial to select **BATTERY TYPE**, and press the **DATA** dial.

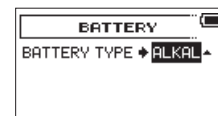

5. Turn the **DATA** dial to set the type of battery used.
Options: ALKAL (alkaline batteries, default), Ni-MH (nickel-metal hydride batteries)
6. When finished, press the **1/■** button to return to the Home Screen.

Setting the file name format

You can select the format of names given to files recorded by this unit.

1. Press the **MENU** button to open the MENU screen.
2. Turn the **DATA** dial to select OTHERS, and press the **DATA** dial to open the OTHERS screen.
3. Turn the **DATA** dial to select FILE NAME, and press the **DATA** dial.

The FILE NAME screen appears.

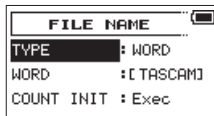

Use the **4/|◀◀** and **3/▶▶|** buttons or turn the **DATA** dial to set each item.

On this screen you can make the following settings for each item.

File name format

The TYPE item can be set to either WORD or DATE.

WORD (default): The 6 characters set with the WORD item is used for file names.

Example: TASCAM_0001S12.wav

DATE: The date is used for the file name.

Example: 141001_0001S12.wav

NOTE

The date is set using the unit's internal clock. (See "Setting the date and time" on page 14.)

Setting the WORD item

To set the WORD item, use the **4/|◀◀** and **3/▶▶|** buttons to move the cursor, and turn the **DATA** dial to select the character.

In addition to the alphabet and numbers, the following characters can be used:

! # \$ % & ' () + , - . ; = @ [\] ^ _ ` { } ~

Initializing the count

You can select the COUNT INIT item and press the **DATA** dial to reset the incremental numbers, which appear after the WORD characters or date, so that they start from "0001" again.

9 – Using the REMOTE jack

This unit has a **REMOTE** jack.

You can connect a TASCAM RC-3F footswitch or TASCAM RC-10 wired remote control (both sold separately) to it and use the remote to operate the unit.

Using a footswitch (TASCAM RC-3F)

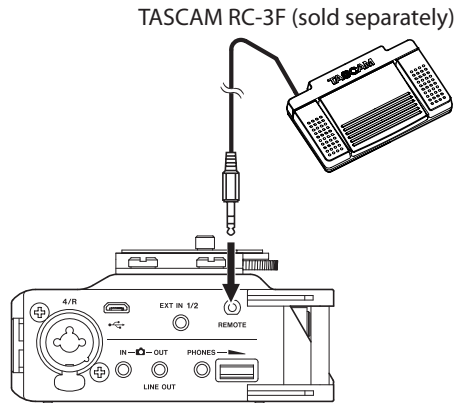

Making footswitch settings

Make footswitch settings on the **REMOTE** screen.

1. Press the **MENU** button to open the **MENU** screen.
2. Turn the **DATA** dial to select **OTHERS**, and press the **DATA** dial to open the **OTHERS** screen.
3. Turn the **DATA** dial to select **REMOTE**, and press the **DATA** dial to open the **REMOTE** screen.

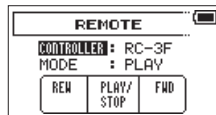

4. Turn the **DATA** dial to select **CONTROLLER**, and press the **DATA** dial.
5. Turn the **DATA** dial to select **RC-3F**. (Default: RC-3F)

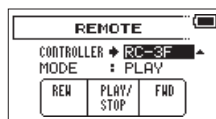

6. Use the **4/I** button and the **DATA** dial to select **MODE**, and press the **DATA** dial.
7. Turn the **DATA** dial to set the footswitch mode.
Options: **PLAY** (default), **RECORD1**, **RECORD2**

MODE	Footswitch		
	L	C	R
PLAY	REW	PLAY/STOP	FWD
RECORD1	STOP	REC	INC
RECORD2	STOP	REC	SLATE

INC: Track incrementing function

(All other functions are the same as on the main unit.)

8. When finished, press the **1/■** button to return to the Home Screen.

Footswitch uses

Press the pedals on the footswitch to conduct the operations assigned on the **REMOTE** screen.

Using a remote control (TASCAM RC-10)

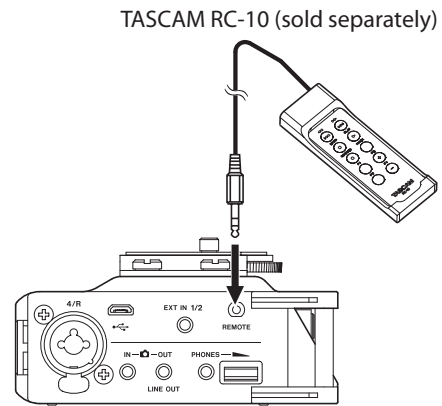

Making remote control settings

Make remote control settings on the **REMOTE** screen.

1. Press the **MENU** button to open the **MENU** screen.
2. Turn the **DATA** dial to select **OTHERS**, and press the **DATA** dial to open the **OTHERS** screen.
3. Turn the **DATA** dial to select **REMOTE**, and press the **DATA** dial to open the **REMOTE** screen.
4. Turn the **DATA** dial to select **CONTROLLER**, and press the **DATA** dial.
5. Turn the **DATA** dial to select **RC-10**. (Default: RC-3F)

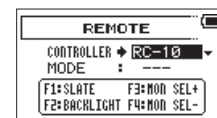

6. When finished, press the **1/■** button to return to the Home Screen.

Remote control uses

Press the function (F1-F4) buttons on the TASCAM RC-10 remote control to conduct the operations assigned on the **REMOTE** screen.

Function buttons			
F1	F2	F3	F4
SLATE	Backlight Always ON/ Backlight OFF	CAMERA/MIX	CAMERA/MIX

10 – Messages

The following is a list of the pop-up messages.

Refer to this list if one of these pop-up messages appears on the DR-70D and you want to check the meaning or determine a proper response.

Message	Meaning and response
Battery Empty	The batteries are almost out of power. Replace the batteries.
Card Error	The SD card could not be recognized properly. Change the card.
Card Full	The SD card has no remaining space. Erase unnecessary files or move them to a computer to make open space.
File Full	The total number of folders and files exceeds the limit of 5000. Erase unnecessary folders and files or move them to a computer.
File Not Found	A file cannot be found or a file might be damaged. Please check that file.
File Not Found Make Sys File	The system file is missing. This unit requires a system file for operation. When this message appears, press the DATA dial to automatically create a system file.
File Protected	The file is read only and cannot be erased.
Format Error Format CARD	The SD card is not formatted properly or the card is broken. This message also appears if the card was formatted using a computer connected by USB or if an unformatted card is inserted in the unit. Always use the DR-70D to format cards to be used with it. Change the card or press the DATA dial while this message is being shown to format the card. Formatting will erase all the data on the SD card.
Invalid Card Change Card	Something might be wrong with the SD card. Change the SD card.
Invalid SysFile Make Sys File	The system file required to operate this unit is invalid. When this message appears, press the DATA dial to automatically create a new system file.
Layer too Deep	Folders can be created down to two layers. You cannot create a new folder inside the current folder.
MBR Error Init CARD	The SD card is not formatted properly or the card is broken. Change the card or press the DATA dial while this message is being shown to format the card. Formatting will erase all the data on the SD card.
No Card	No SD card is loaded in the unit. Insert a recordable SD card.
No PB File	There is no file that can be played back. The file might be damaged.
Non-Supported	The audio file is not a supported format. Please see "7 – Connecting with a Computer" for file formats that this unit can use.
Switched To Internal Battery	The power source has switched from USB bus power to the batteries in the unit.
Write Timeout	Writing to the SD card timed out. Backup files on the card to a computer, and format the card.
No Rec Channels Selected	No recording channels have been selected (all are off).

Message	Meaning and response
Not Possible Check FILE TYPE	The setting cannot be changed. Change the FILE TYPE setting to MONO or STEREO.
Not Possible Check INPUT3/4	The setting cannot be changed. Change the INPUT 3/4 setting to XLR/TRS.
Not Possible Check Rec Chs	The setting cannot be changed. Check the recording channels.
Not Possible Set DUAL-REC OFF	The setting cannot be changed. Turn DUAL REC mode off.
Can't Save Data	<p>If any of these errors occurs, turn the unit's power off and restart it.</p> <p>If the power cannot be turned off, remove the batteries and disconnect the AC adapter (TASCAM PS-P515U) or disconnect the USB cable if using USB bus power.</p> <p>If the error message continues to appear frequently, please contact a TEAC Repair Center (See back cover).</p>
Device Error	
File Error	
Not Continued	
Player Error	
Remote Cmd	
Remote Rx	
Writing Failed	
Sys Rom Err	
System Err 50	
System Error 1	
System Error 2	
System Error 3	
System Error 4	
System Error 5	
System Error 6	
System Error 7	
System Error 8	
System Error 9	

11 – Troubleshooting

If you are having trouble with the operation of this unit, please try the following before seeking repair. If these measures do not solve the problem, please contact the store where you bought the unit or TEAC customer support (See back cover).

■ The unit will not turn on.

- Confirm that the batteries are not dead.
- Confirm that the batteries are installed with the correct ⊕/⊖ orientation.
- Confirm that the AC adapter (TASCAM PS-P515U, sold separately) is securely connected to both the outlet and the unit.
- When using USB bus power, confirm that the USB cable is securely connected.
- When using USB bus power, confirm that it is not connected via a USB hub.

■ The unit turns off automatically.

Is the automatic power saving function on? (See “Setting the automatic power saving function” on page 34.)

- Since this unit complies with the European Standby Power Regulations (ErP), the automatic power saving function operates regardless of whether the unit is being powered by an AC adapter or batteries. If you do not want to use the automatic power saving function, set it to “OFF”. (The factory default setting is “30min”.)

■ The unit does not function.

- Confirm that the **HOLD**/⏻/ I switch is not set to **HOLD**.
- Is the unit connected to a computer by a USB cable? (Does **USB connected** appear on the display?)

■ The SD card is not recognized.

- Confirm that the SD card is inserted completely.

■ Playback is not possible.

- If you are trying to play a WAV file, confirm that the sampling frequency is supported by this unit.

■ No sound is output.

- Check the connections with the monitoring system.
- Is the volume of the monitoring system minimized?
- Is the **OUTPUT LEVEL** setting of the unit minimized?

■ Recording is not possible.

- If you are using an external device, check the connection again.
- Check the input settings again.
- Confirm that the input level is not too low.
- Confirm that the SD card is not full.
- Confirm that the number of files has not reached the maximum that the unit can handle.

■ The input level is low.

- Confirm that the input level setting is not too low.
- Confirm that the output level of any connected device is not too low.

■ The sound I am trying to record sounds distorted.

- Confirm that the input level setting is not too high.

■ Adjust the input knobs so that the PEAK indicators do not light.

- Lower the volumes of the sound sources being input to this unit.

■ I cannot erase a file.

- Confirm that you are not trying to erase a file that has been copied from a computer after being write-protected.

■ This unit's files do not appear on the computer.

- Confirm that the unit is connected to the computer using its USB port.
- Confirm that no USB hub is being used.
- Confirm that the unit is not recording.

12 – Specifications

Ratings

■ Recording media

SD card (64 MB – 2 GB)
SDHC card (4 GB – 32 GB)
SDXC card (48 GB – 128 GB)

■ Recording/playback formats

WAV: 44.1/48/96kHz, 16/24 bit
BWF: 44.1/48/96kHz, 16/24 bit

■ Number of channels

4 maximum (stereo × 2, mono × 4)

Input/output ratings

Analog audio input and output ratings

■ 1/L, 2/R, 3/L, 4/R jacks (can provide phantom power)

Connectors:

XLR-3-31
(1: GND, 2: HOT, 3: COLD)
6.3mm (1/4") standard TRS jacks
(Tip: HOT, Ring: COLD, Sleeve: GND)

When input gain set to MIC or MIC+PHANTOM

Input impedance: 2 k Ω
Phantom power: 48V \pm 4V (10mA/CH) or 24V \pm 4V (10mA/CH)

Maximum input level: 0 dBu
Minimum input level: –72 dBu
Mic input gain (when TRIM at maximum)
LOW: +21 dB
MID: +36 dB
HIGH: +51 dB
HI+PLUS: +63 dB

When input gain set to LINE

Input impedance: 10 k Ω or more
Nominal input level: +4 dBu
Maximum input level: +20 dBu

■ EXT IN 1/2 jack (can provide plug-in power)

Connector: 3.5mm (1/8") stereo mini jack
Input impedance: 10 k Ω
Maximum input level: +10 dBV
Minimum input level: –50 dBV
Mic input gain (when TRIM at maximum)
LOW: +3 dB
MID: +11 dB
HIGH: +26 dB
HI+PLUS: +38 dB

■ IN connector

Connector: 3.5mm (1/8") stereo mini jack
Input impedance: 10 k Ω
Nominal input level: –10 dBV
Maximum input level: +6 dBV

■ PHONES jack

Connector: 3.5mm (1/8") stereo mini jack
Maximum output: 20 mW + 20 mW

■ OUT/LINE OUT jack

Connector: 3.5mm (1/8") stereo mini jack
Output impedance: 200 Ω
When set to CAMERA OUT
Nominal output level: –40 dBV
Maximum output level: –24 dBV
When set to LINE OUT
Nominal output level: –10 dBV
Maximum output level: +6 dBV

Notes:

Maximum input level: Level when input knob is adjusted and a digital full scale signal (0dBFS) can be input without distorting

Minimum input level: Level when input knob is adjusted and a –20dBFS signal can be input

Control input/output ratings

■ USB port

Connector type: Micro-B
Format: USB 2.0 HIGH SPEED mass storage class

■ REMOTE jack

Connector: 2.5mm (3/32") TRS jack

Audio performance

■ Frequency response

20–20 kHz +0.5/–2 dB
(LINE IN or MIC IN to LINE OUT, Fs 44.1/48kHz, JEITA)
20–40 kHz +0.5/–3 dB
(LINE IN or MIC IN to LINE OUT, Fs 96kHz, JEITA)

■ Distortion

0.02% or less
(LINE IN or MIC IN to LINE OUT, Fs 44.1/48/96kHz, JEITA)

■ S/N ratio

92 dB or higher
(LINE IN or MIC IN to LINE OUT, Fs 44.1/48/96kHz, JEITA)

■ Equivalent input noise (EIN)

–120 dBu or less
Note: based on JEITA CP-2150

12 – Specifications

Requirements for connected computers

Check the TEAC Global Site (<http://teac-global.com/>) for the latest information about supported operating systems.

■ Windows PC

- Pentium 300 MHz or faster
- 128 MB or more memory
- USB port (USB 2.0 recommended)

■ Mac

- Power PC, iMac, G3, G4 266 MHz or faster
- 64 MB or more memory
- USB port (USB 2.0 recommended)

■ Recommended USB host controller

- Intel chipset

■ Supported operating systems

- Windows XP, Windows Vista, Windows 7, Windows 8 (including 8.1)
- Mac OS X 10.2 or newer

General

■ Power

- 4 AA batteries (alkaline or NiMH)
- USB bus power from a computer
- AC adapter (TASCAM PS-P515U, sold separately)
- Using an external battery pack (TASCAM BP-6AA, sold separately)

■ Power consumption

- 5.0W (maximum)

■ Current consumption (USB bus power)

- 1 A (maximum)

■ Battery operation time (continuous operation)

- Using alkaline batteries (EVOLTA)

Format	Operation time (in hours: minutes)	Note
Recording 2ch 44.1kHz/16-bit WAV files	About 6:00	When XLR/TRS input selected (phantom power not used)
Recording 2ch 44.1kHz/16-bit WAV files	About 3:30	When XLR/TRS input selected (phantom power used)
Recording 2ch 44.1kHz/16-bit WAV files	About 11:00	When 3/4 MIC input (built-in mic) selected

- Using NiMH battery (eneloop)

Format	Operation time (in hours: minutes)	Note
Recording 2ch 44.1kHz/16-bit WAV files	About 6:15	When XLR/TRS input selected (phantom power not used)

Recording 2ch 44.1kHz/16-bit WAV files	About 3:15	When XLR/TRS input selected (phantom power used)
Recording 2ch 44.1kHz/16-bit WAV files	About 10:30	When 3/4 MIC input (built-in mic) selected

- Using NiMH battery (eneloop-pro)

Format	Operation time (in hours: minutes)	Note
Recording 2ch 44.1kHz/16-bit WAV files	About 7:45	When XLR/TRS input selected (phantom power not used)
Recording 2ch 44.1kHz/16-bit WAV files	About 4:45	When XLR/TRS input selected (phantom power used)
Recording 2ch 44.1kHz/16-bit WAV files	About 14:15	When 3/4 MIC input (built-in mic) selected

■ Battery operation time (continuous operation) when using TASCAM BP-6AA (sold separately)

- Using alkaline batteries (EVOLTA) + BP-6AA (EVOLTA)

Format	Operation time (in hours: minutes)	Note
Recording 2ch 44.1kHz/16-bit WAV files	About 13:00	When XLR/TRS input selected (phantom power not used)
Recording 2ch 44.1kHz/16-bit WAV files	About 7:30	When XLR/TRS input selected (phantom power used)
Recording 2ch 44.1kHz/16-bit WAV files	About 25:30	When 3/4 MIC input (built-in mic) selected

- Using NiMH batteries (eneloop pro) + BP-6AA (EVOLTA)

Format	Operation time (in hours: minutes)	Note
Recording 2ch 44.1kHz/16-bit WAV files	About 12:45	When XLR/TRS input selected (phantom power not used)
Recording 2ch 44.1kHz/16-bit WAV files	About 7:45	When XLR/TRS input selected (phantom power used)
Recording 2ch 44.1kHz/16-bit WAV files	About 24:45	When 3/4 MIC input (built-in mic) selected

- Using NiMH batteries (eneloop pro) + BP-6AA (EVOLTA)

Format	Operation time (in hours: minutes)	Note
Recording 2ch 44.1kHz/16-bit WAV files	About 14:30	When XLR/TRS input selected (phantom power not used)

Recording 2ch 44.1kHz/16-bit WAV files	About 8:45	When XLR/TRS input selected (phantom power used)
Recording 2ch 44.1kHz/16-bit WAV files	About 27:00	When 3/4 MIC input (built-in mic) selected

NOTE

When using phantom power, the operation time might be reduced depending on the mic being used.

■ Dimensions

169 × 55.2 × 106.5 mm (W × H × D with top adapter attached)

■ Weight

625 g (including batteries)/530 g (not including batteries)

■ Operating temperature range

0°C – 40°C (32°F – 104°F)

Dimensional drawings

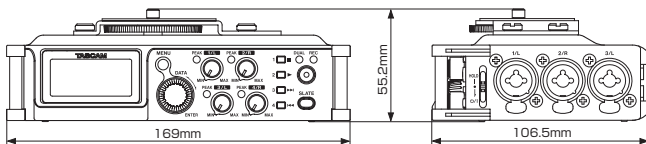

- Illustrations in this manual might differ in part from the actual product.
- Specifications and external appearance might be changed without notification to improve the product.

TASCAM

TEAC CORPORATION

Phone: +81-42-356-9143
1-47 Ochiai, Tama-shi, Tokyo 206-8530 Japan

<http://tascam.jp/>

TEAC AMERICA, INC.

Phone: +1-323-726-0303
1834 Gage Road, Montebello, California 90640 USA

<http://tascam.com/>

TEAC MEXICO, S.A. de C.V.

Phone: +52-55-5010-6000
Río Churubusco 364, Colonia Del Carmen, Delegación Coyoacán, CP 04100, México DF, México

<http://teacmexico.net/>

TEAC UK Ltd.

Phone: +44-8451-302511
2 Huxley Road, Surrey Research Park Guildford, GU2 7RE, United Kingdom

<http://tascam.eu/>

TEAC EUROPE GmbH

Phone: +49-611-71580
Bahnstrasse 12, 65205 Wiesbaden-Erbenheim, Germany

<http://tascam.eu/>

TEAC SALES & TRADING(SHENZHEN) CO., LTD

Phone: +86-755-88311561~2
Room 817, Block A, Hailrun Complex, 6021 Shennan Blvd., Futian District, Shenzhen 518040, China

<http://tascam.cn/>
